

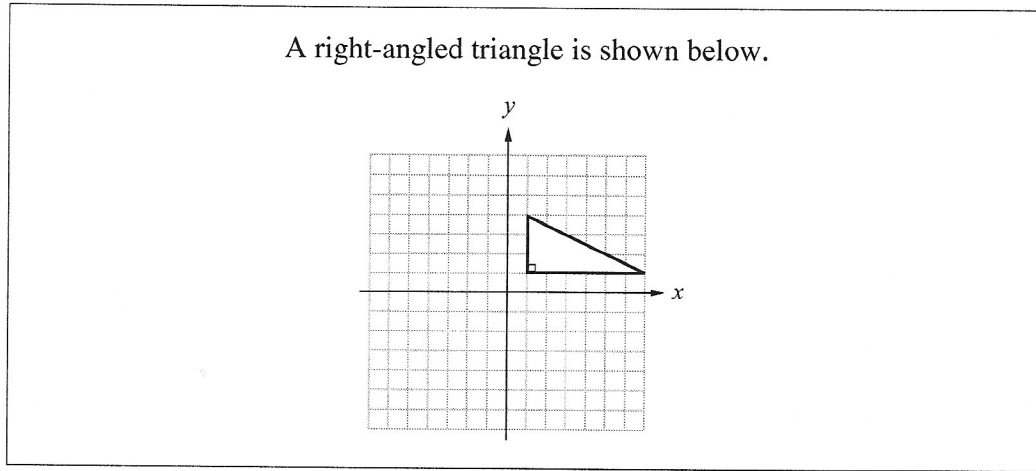

## Connections within Mathematics

Use the following information to answer question 1.



1. Which of the following diagrams represents the triangle above when it is reflected using the  $x$ -axis as the line of reflection?

A.

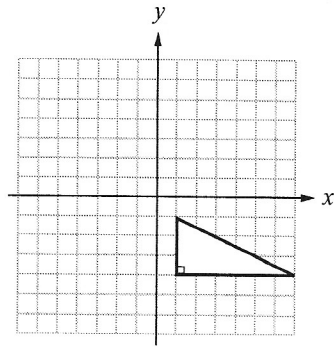

B.

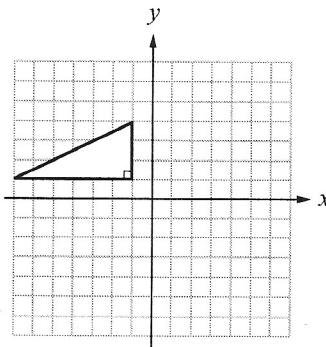

C.

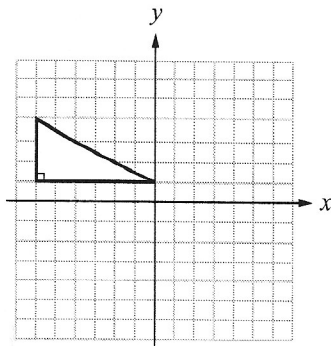

D.

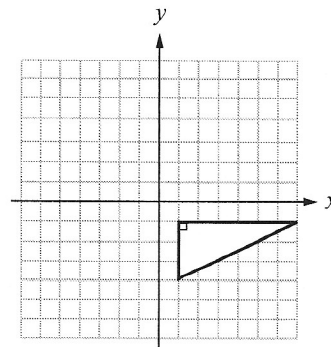

Use the following algebra-tile legend to answer questions 2 and 3.

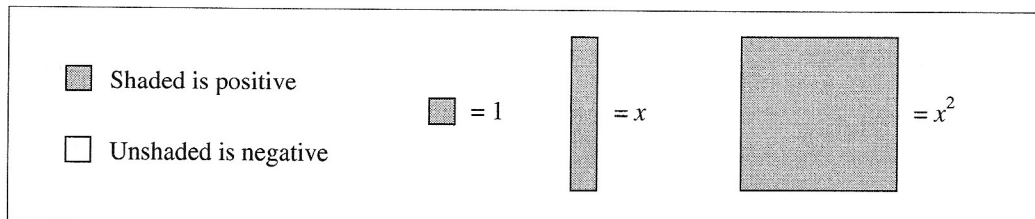

2. Which of the following area diagrams represents the product of  $(x + 3)(x - 4)$ ?

A.

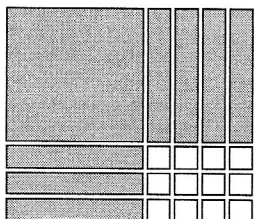

B.

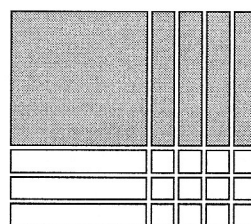

C.

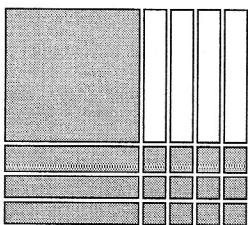

D.

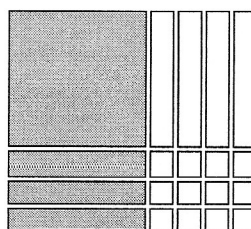

3. Kent and Larissa go to a movie. Admission is  $x$  dollars per person. They have a \$5 discount coupon. Which of the following algebra-tile models represents a mathematical expression for what they pay?

A.

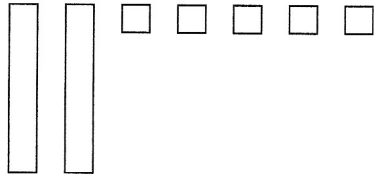

B.

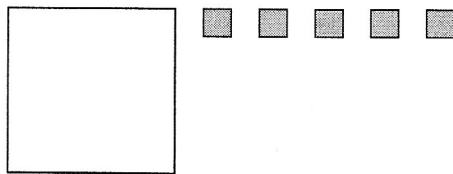

C.

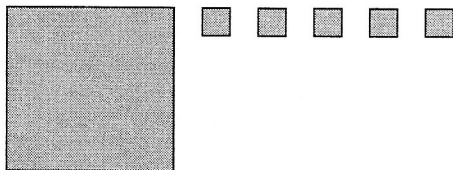

D.

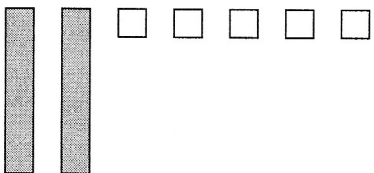

Use the following information to answer question 4.

On the grid below, the original image is  $\triangle ABC$  and the dilatation image is  $\triangle A'B'C'$ .

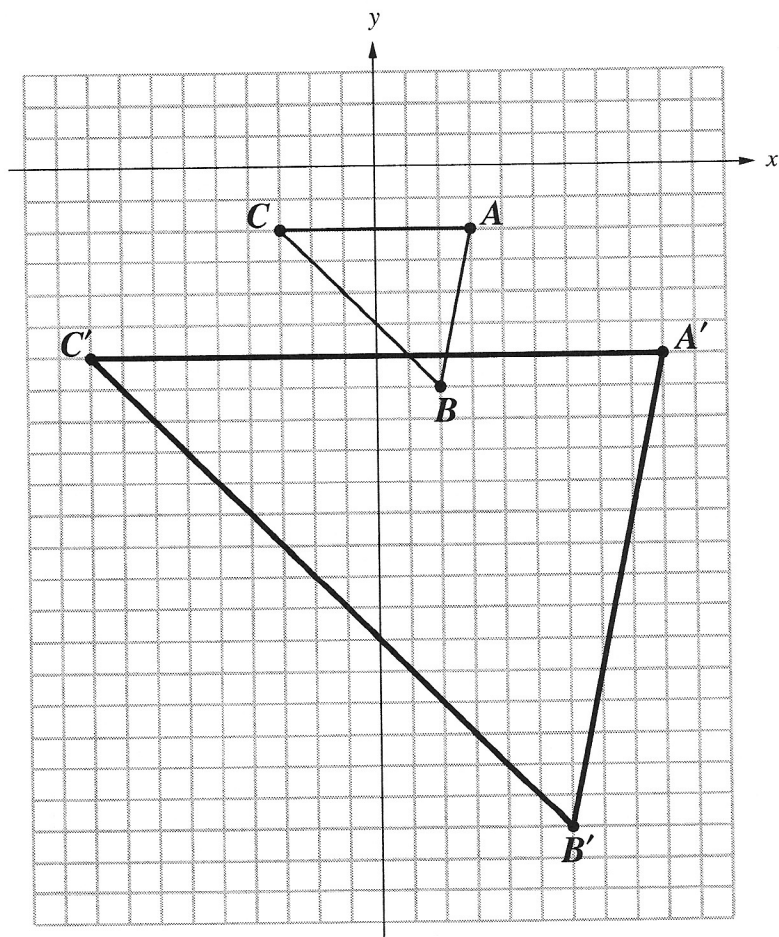

4. The scale factor of the dilatation is

- A.  $\frac{1}{4}$
- B.  $\frac{1}{3}$
- C. 3
- D. 4

Use the following information to answer question 5.

A home builder is installing carpet in a new home. The area, in square metres, of the living room can be expressed as  $x^2 - 8x + 15$ .

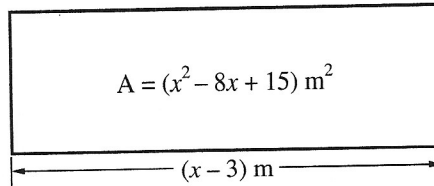

5. If the length of this room is represented by  $(x - 3) \text{ m}$ , then the width is represented by
- A.  $(x - 5) \text{ m}$
  - B.  $(x + 5) \text{ m}$
  - C.  $(7x - 5) \text{ m}$
  - D.  $(-7x + 5) \text{ m}$

6. Which of the following number lines represents the solution to the inequality  $x + 8 > 3x - 6$ ,  $x \in \mathbb{R}$ ?

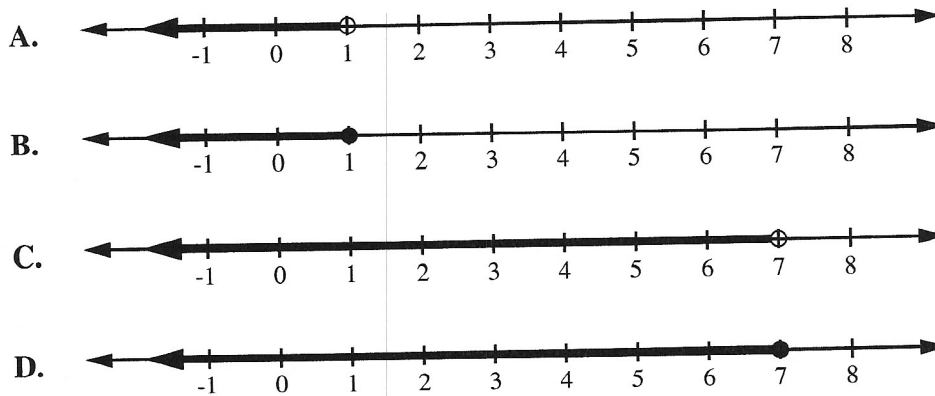

7. The calculator keystroke sequence that would give the solution of  $\frac{28+7}{5 \times (4+3)}$  is

A. 28  7  5  4  3

B.  28  7   5   4  3

C. 28  7   5   4  3

D.  28  7    5   4  3

8. If  $2x + 23 = -7 + 8x$ , then  $x$  equals

A. 5

B. 3

C. -3

D. -5

9. A square has an area of  $196 \text{ cm}^2$ . Given that  $\pi = 3.14$ , what is the area of the largest circle that can be drawn within this square?

A.  $615.44 \text{ cm}^2$

B.  $153.86 \text{ cm}^2$

C.  $62.42 \text{ cm}^2$

D.  $43.96 \text{ cm}^2$

10. You are asked to conduct a survey to determine the favourite sport of people attending a co-ed camp. Which of the following samples is **least** biased?
- A. A sample of all campers
  - B. A sample of all of the boys at camp
  - C. A sample of the camp football team
  - D. A sample of spectators at a camp soccer game

Use the following information to answer question 11.

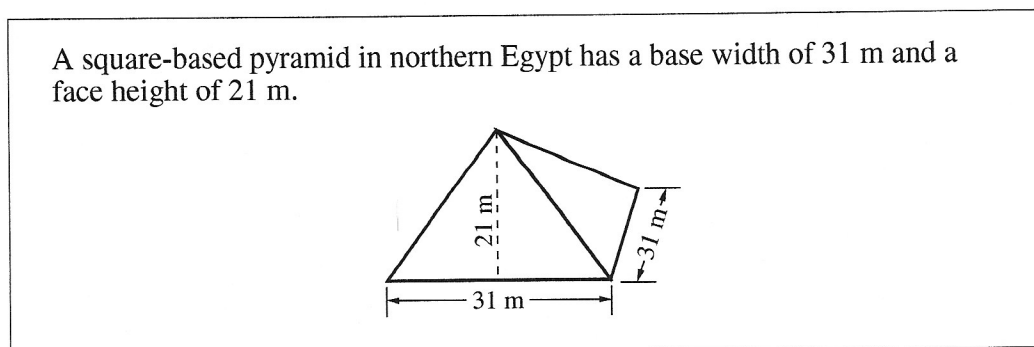

11. The total surface area of the 4 exposed faces of this pyramid is
- A. 2 604.0 m<sup>2</sup>
  - B. 1 302.0 m<sup>2</sup>
  - C. 651.0 m<sup>2</sup>
  - D. 325.5 m<sup>2</sup>
- 
12. Alex runs on a treadmill and consumes about  $5 \times 10^5$  joules (J) of energy every 15 minutes. At this rate of energy consumption, if Alex runs for  $1\frac{3}{4}$  hours, the amount of energy he uses, expressed in **scientific notation**, is approximately
- A.  $3.5 \times 10^6$  J
  - B.  $35 \times 10^5$  J
  - C.  $8.75 \times 10^5$  J
  - D.  $87.5 \times 10^4$  J



13. During badminton intramurals, 5 players compete in round robin play where each player plays every other player one game. No tiebreaker games are required. The two players who win the most games meet in a final playoff game. Including the final game, how many games must be scheduled?
- A. 26 games
  - B. 21 games
  - C. 11 games
  - D. 6 games
14. What is the value of  $\frac{(-2)^7}{4^0}$ ?
- A. +128
  - B. -128
  - C. 0
  - D. Undefined

Use the following scatter plot to answer question 15.

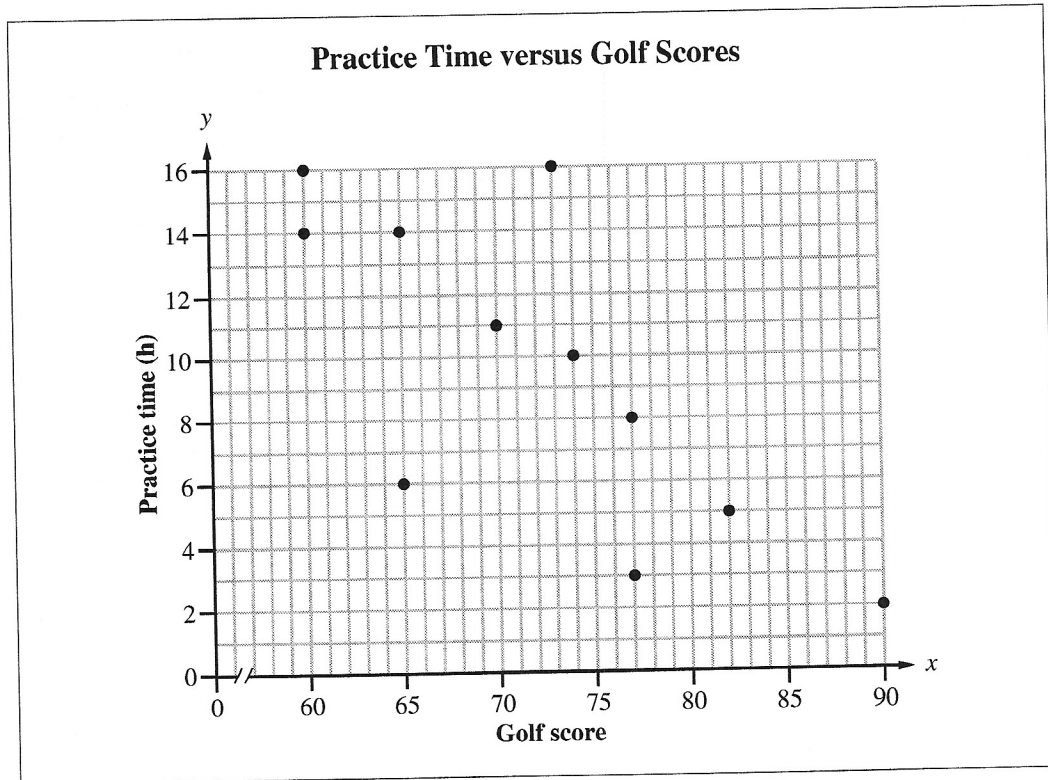

15. If a line of best fit were drawn on the scatter plot above, the coordinate point that would lie closest to the line of best fit would be
- A. (60, 14)
  - B. (65, 6)
  - C. (73, 16)
  - D. (77, 8)

## Mathematics of Farming

Farmers use math everyday. The following questions show ways in which farmers may use math in their daily work.

16. A farmer and his son leave a barn at the same time and walk in opposite directions checking a fence line. The son walks at a speed of 3.5 km/h, and the farmer at 4.0 km/h. How much time will have elapsed when the farmer and his son are 2.5 km apart?
- A.  $\frac{1}{5}$  h
  - B.  $\frac{1}{3}$  h
  - C. 3 h
  - D. 5 h
17. On Monday, the farmer's hens laid 50 eggs. Of the 50 eggs, 35 were white, and 15 were brown. When the farmer gathered the eggs, what is the probability that the first egg he randomly picked was a white egg?
- A.  $\frac{1}{50}$
  - B.  $\frac{1}{35}$
  - C.  $\frac{15}{35}$
  - D.  $\frac{35}{50}$

Use the following information to answer question 18.

The farmer's son makes a work arrangement with his father. In return for unlimited use of a truck for one year, he agrees to pay the following estimated yearly truck expenses.

• Insurance	\$556.40
• Gasoline	\$1 040.40
• Repairs	\$800.00
• Maintenance	\$200.00

The son also wishes to earn \$2 000.00 above these truck expenses.

18. The son works 8 hours a week for 52 weeks on the farm. What is the **lowest** hourly wage he must earn in order to pay these truck expenses for one year and also save \$2 000.00?
- A. \$6.25/h
  - B. \$10.50/h
  - C. \$11.05/h
  - D. \$12.50/h

Use the following information to answer question 19.

A conveyor belt is used to move hay bales from the ground to the top of a haystack. The loading end of the conveyor belt is 7.3 m from the haystack. Each hay bale moves 8.0 m along the conveyor belt.

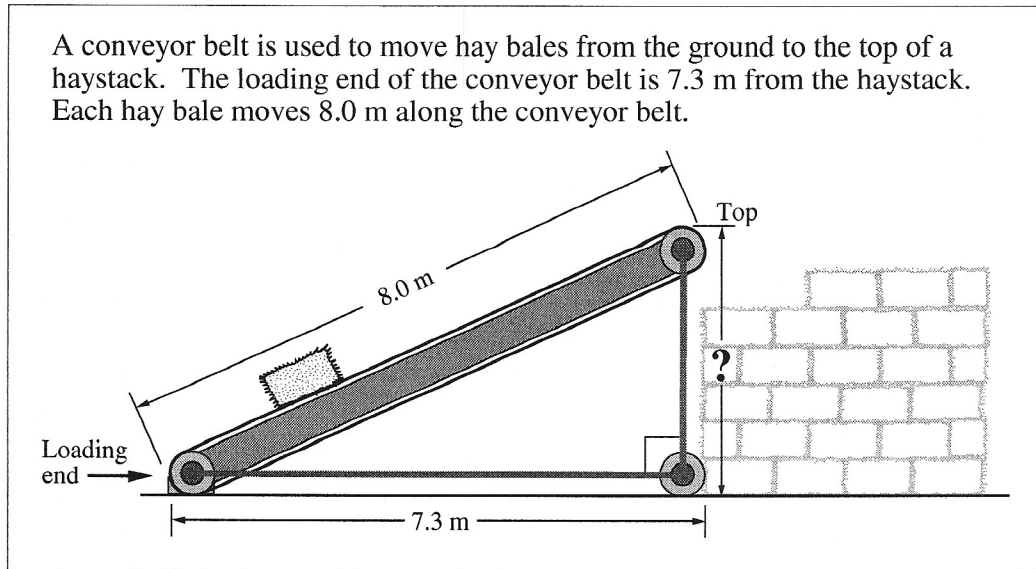

19. What is the height to the top of the conveyor belt?

- A. 2.6 m
- B. 3.3 m
- C. 6.8 m
- D. 10.7 m

Use the following picture to answer question 20.

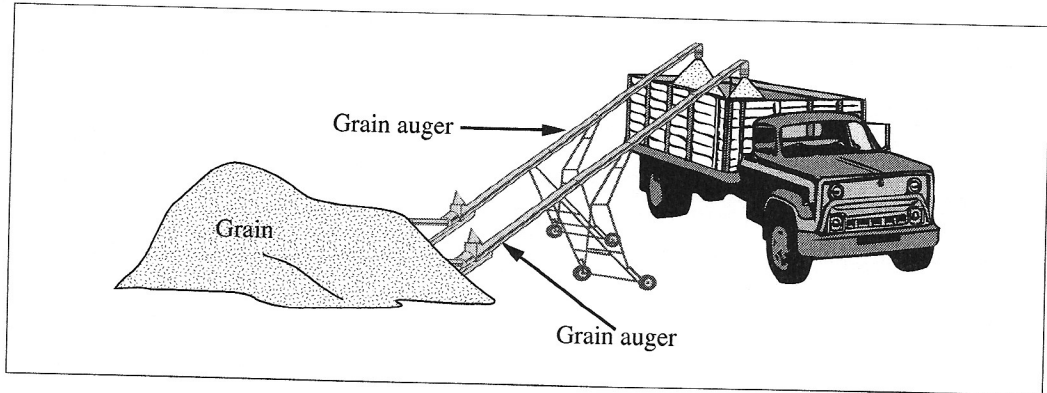

20. At the farm, two augers are being used to fill a truck with grain. One auger alone can fill the truck in 15 minutes. The other auger alone can fill the truck in 10 minutes. How long will it take the two augers together to fill the truck?
- A. 5.5 min
  - B. 6.0 min
  - C. 12.5 min
  - D. 25.0 min

21. In the fall, the farmer sells his grain. Which of the following graphs shows the relationship between grain price and farm income?

A.

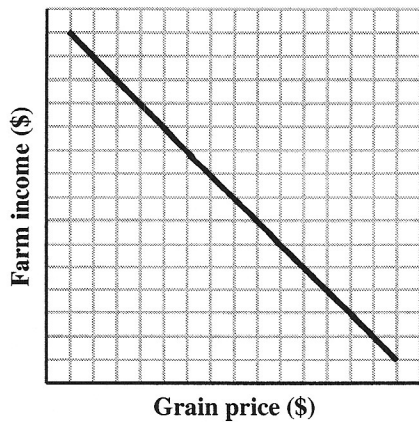

B.

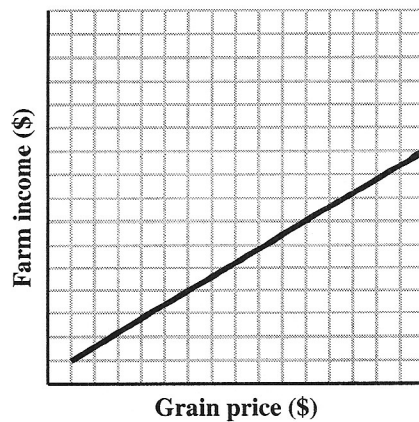

C.

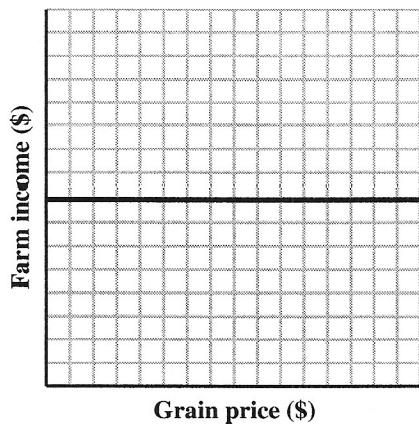

D.

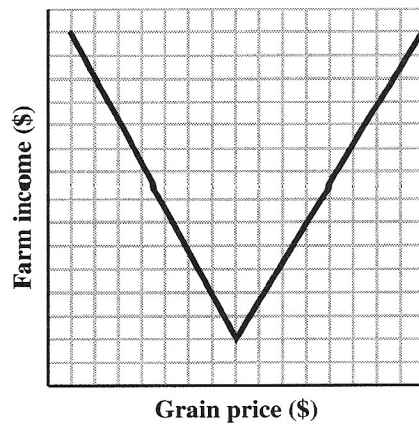

22. A surveyor's report states that a field being planted measures 302 m by 604 m. A farmer spreads seed at a rate of 2.7 kg for every 100 m<sup>2</sup>. Given that 1 t = 1 000 kg, approximately how many tonnes (t) of seed are needed to plant the entire field?
- A. 5 t
  - B. 25 t
  - C. 65 t
  - D. 651 t

*Use the following information to answer question 23.*

A farmer hires a worker. Each week, the worker works 9 h at a rate of \$5.60/h. From each weekly paycheque, the worker must pay

- 1% of the total pay for disability insurance
- 2.2% of the total pay for employment insurance
- 15% of the total pay for income tax and Canada Pension

23. What are the worker's weekly earnings after these deductions are made?
- A. \$50.40
  - B. \$41.48
  - C. \$41.23
  - D. \$32.20



Use the following diagram to answer question 24.

The farmer builds a ramp to load cattle into a truck. The truck deck is 1 m above the ground, and the base of the ramp is 5.65 m long.

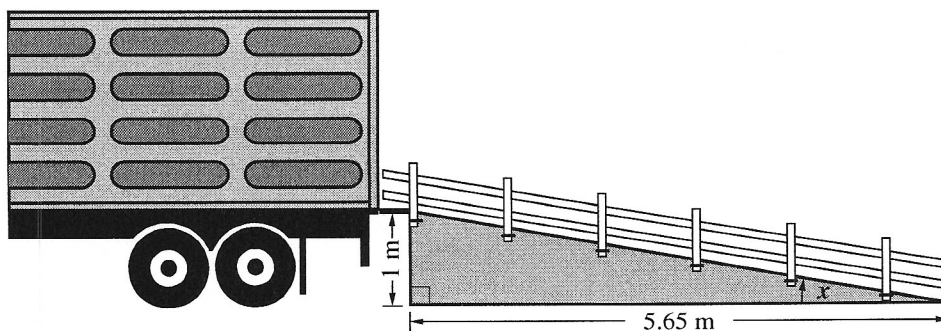

24. What is the angle of inclination ( $x$ ) of the ramp?
- A.  $10.0^\circ$
  - B.  $17.0^\circ$
  - C.  $27.0^\circ$
  - D.  $45.0^\circ$

## Mathematics at the Cabin

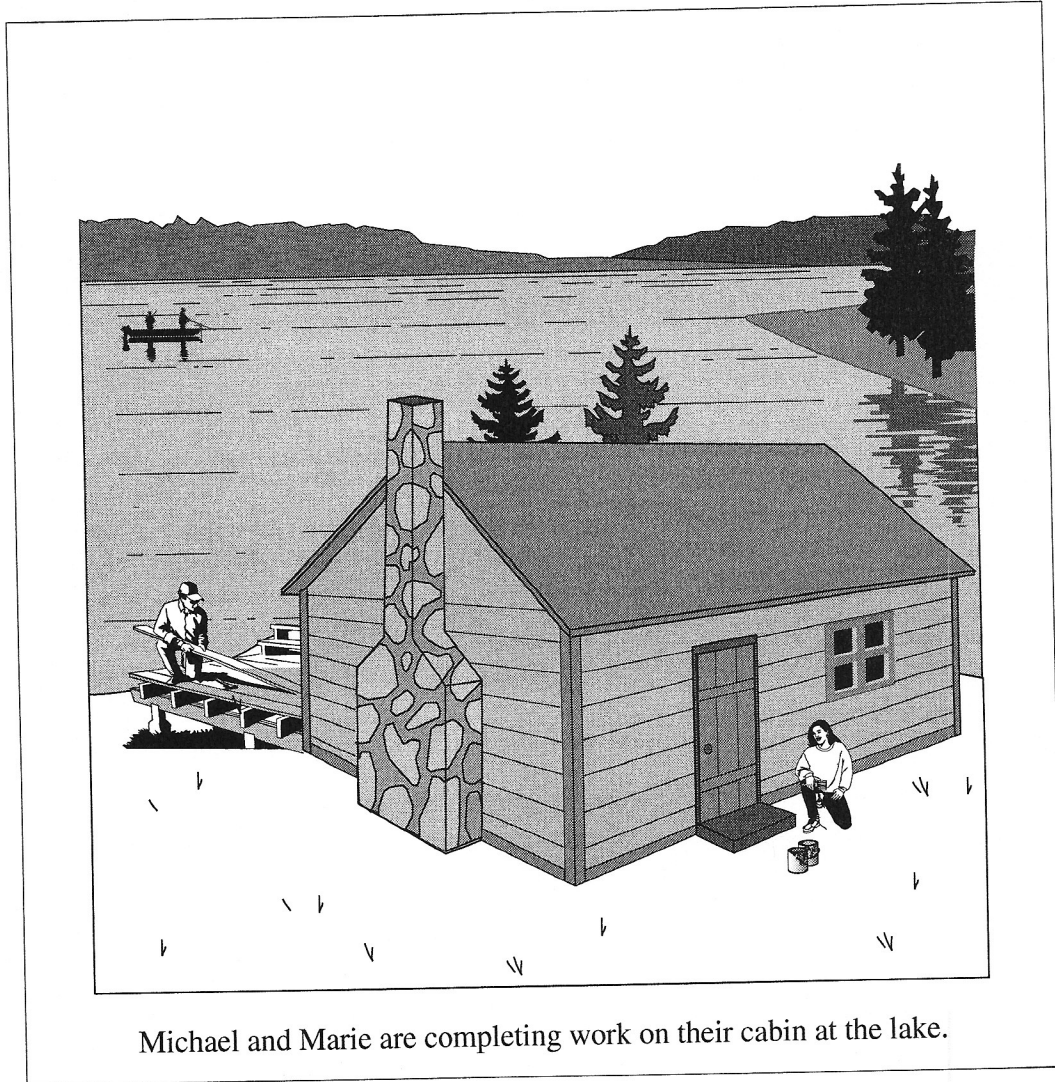

Michael and Marie are completing work on their cabin at the lake.

Use the following information to answer question 25.

Michael stacks boxes of building materials in his storage shed.

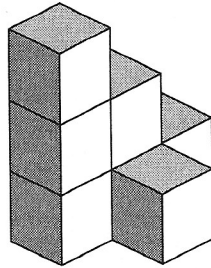

25. Which of the following sets of views represents the layout of Michael's boxes?

A.

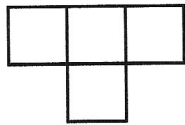

Plan or Top view

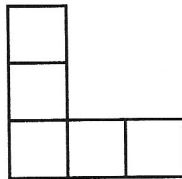

Front view

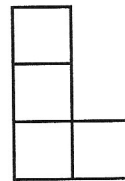

Side view

B.

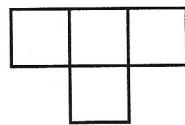

Plan or Top view

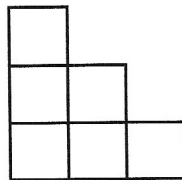

Front view

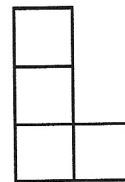

Side view

C.

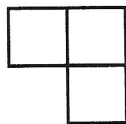

Plan or Top view

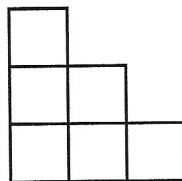

Front view

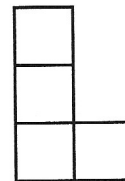

Side view

D.

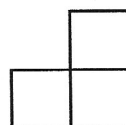

Plan or Top view

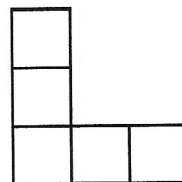

Front view

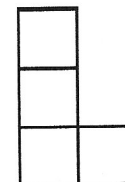

Side view

26. Michael is 1.7 m tall. At 2:00 P.M., he casts a shadow 90 cm long and the cabin casts a shadow 305 cm long. The height of the cabin, to the nearest tenth of a metre, is
- A. 0.5 m
  - B. 2.0 m
  - C. 4.7 m
  - D. 5.8 m
27. Michael buys a fan for the cabin. The store purchased the fan for \$60. The store then marked up the price by 20%. When the fan went on sale, it was decreased by 20%. What was the sale price of the fan that Michael bought?
- A. \$57.60
  - B. \$60.00
  - C. \$60.20
  - D. \$72.00
28. Michael and Marie select wood to build a fence around their cabin property. Out of every 10 pieces of wood they look at, 7 of them are of a good quality and 3 of them have a defect. If Michael and Marie each select 1 piece of wood from a different pile, what is the probability that they both select a good-quality piece?
- A.  $\frac{6}{100}$
  - B.  $\frac{9}{100}$
  - C.  $\frac{14}{100}$
  - D.  $\frac{49}{100}$

29. Michael has a cylindrical rainwater barrel that needs a lid. Which of the following equations could Michael use to determine the radius of the lid?

A.  $r = \frac{2C}{\pi}$

B.  $r = \frac{C}{2\pi}$

C.  $r = \frac{\pi}{2C}$

D.  $r = \frac{2\pi}{C}$

Use the following information to answer question 30.

Marie made an arrangement to buy a used television for a total cost of \$200. She made a \$50 down payment and arranged to make 6 equal payments to pay the balance.

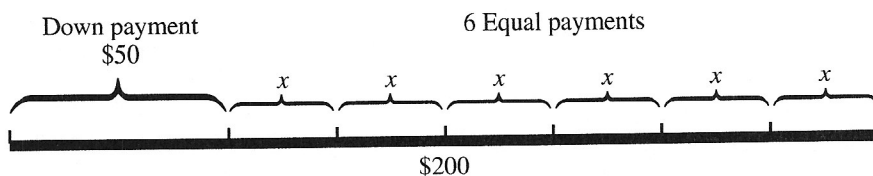

30. Which of the following formulas can Marie use to determine the amount of each of the 6 equal payments?

A.  $x = 200 \div 6 + 50$

B.  $x = (200 + 50) \div 6$

C.  $x = 200 \div 6 - 50$

D.  $x = (200 - 50) \div 6$

31. Marie wants to build a rectangular flower bed. If Marie's flower bed has the greatest possible area within a perimeter of 24 m, then the length of the longest side of her flower bed will be
- A. 6 m
  - B. 7 m
  - C. 10 m
  - D. 11 m

Use the following information to answer question 32.

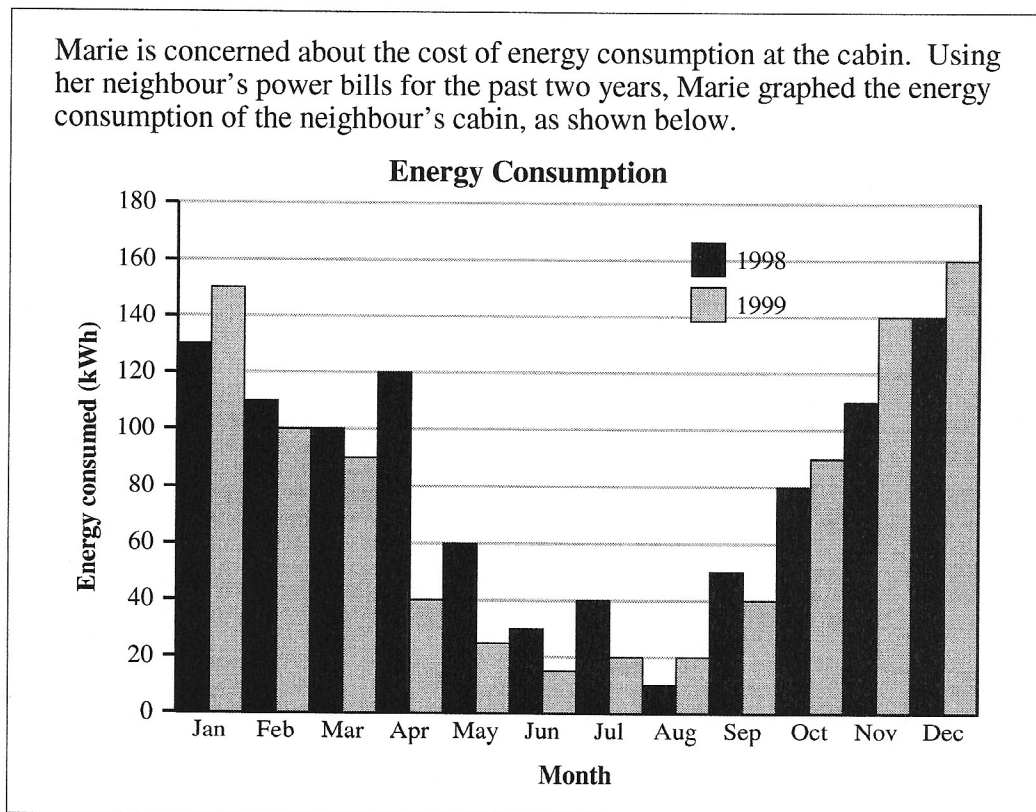

32. When Marie compares the energy consumption for the two years, she realizes that the
- A. July 1999 consumption was one-half the July 1998 consumption
  - B. August 1999 consumption was one-half the August 1998 consumption
  - C. April 1999 consumption was three times as great as the April 1998 consumption
  - D. February 1999 consumption was the same as the February 1998 consumption

## Summer Vacation

Summer vacation has finally arrived! Grade 9 final exams have been completed, and a great summer awaits you. You belong to a travel club, and you are on the way to the airport to fly to London, England, for a one-week holiday.

The questions in this section fall under the sub-headings

- at the airport before departure
- takeoff, flight, and landing
- on tour in London

### At the Airport Before Departure

33. To enter the boarding area, each person walks through a metal detector. If 1 person out of every 10 people sets off the detector, what is the probability that 2 people selected at random will both set off the detector?
- A.  $\frac{1}{10}$
  - B.  $\frac{2}{10}$
  - C.  $\frac{1}{100}$
  - D.  $\frac{81}{100}$

*Use the following information to answer question 34.*

In the boarding area, a vending machine attendant is servicing the machines. In one of the machines, the attendant finds that the dollar coins, quarters, and dimes have a total value of \$67.40. There are 50 more dollar coins than quarters and twice as many dimes as quarters.

34. What is the total value of the dimes the attendant collected?
- A. \$1.20
  - B. \$2.40
  - C. \$12.00
  - D. \$24.00



35. While looking out the windows in the boarding area, you notice a cargo plane being loaded. The total volume of storage space available on the cargo plane is  $1.488 \times 10^3 \text{ m}^3$ . How many crates with a volume of  $1.24 \times 10^1 \text{ m}^3$  can fit in this storage space?
- A.  $1.20 \times 10^4$  crates
  - B.  $1.20 \times 10^3$  crates
  - C.  $1.20 \times 10^2$  crates
  - D.  $1.20 \times 10^1$  crates

### Takeoff, Flight, and Landing

Use the following information to answer question 36.

Your plane requires 20 L of fuel for each kilometre travelled after it reaches cruising altitude.

To determine the total amount of fuel required for a flight ( $F$ ), the pilot also needs to know:

- the amount of fuel needed to reach cruising altitude ( $A$ )
- the distance, in kilometres, travelled after the plane reaches cruising altitude ( $C$ )
- the amount of fuel needed for descent and landing ( $D$ )

36. Which of the following formulas represents the total amount of fuel required for the flight?

- A.  $F = C + A + 20F$
- B.  $F = C + D + 20A$
- C.  $F = A + C + 20D$
- D.  $F = A + D + 20C$

Use the following information to answer question 37.

After takeoff, your plane ascends along its flight path at an angle of  $20^\circ$ .

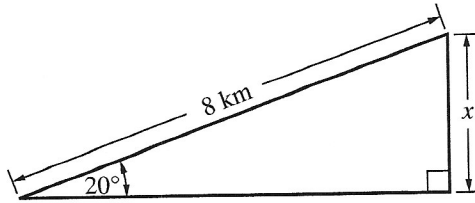

37. A formula that can be used to find the plane's vertical height ( $x$ ), in kilometres, above ground level after it has travelled 8 km along its flight path is

A.  $\sin 20^\circ = \frac{x}{8}$

B.  $\sin 20^\circ = \frac{8}{x}$

C.  $\cos 20^\circ = \frac{x}{8}$

D.  $\cos 20^\circ = \frac{8}{x}$

During the flight to London, you try to solve two puzzles from your Logic Puzzle Magazine.

Use the following puzzle to answer question 38.

**Integer Insanity!**

**Legend**

- X Road block
- Dead end
- H Hotel
- M Museum

N  
↑

To solve this puzzle, let

- positive integers represent movements north or east
- negative integers represent movements south or west
- 1 block = 1 integer value

38. In the first puzzle, which of the following sets of integers represents the shortest route, in blocks, from the hotel to the museum?

- A. +2, +1, +2, -5
- B. -5, +3, +1, +1
- C. +1, +1, +3, -5
- D. -2, +3, -2, +1

39. In the second puzzle, you have 3 consecutive odd numbers whose sum is 219. What is the value of the largest number?
- A. 77
  - B. 75
  - C. 73
  - D. 71

Use the following information to answer question 40.

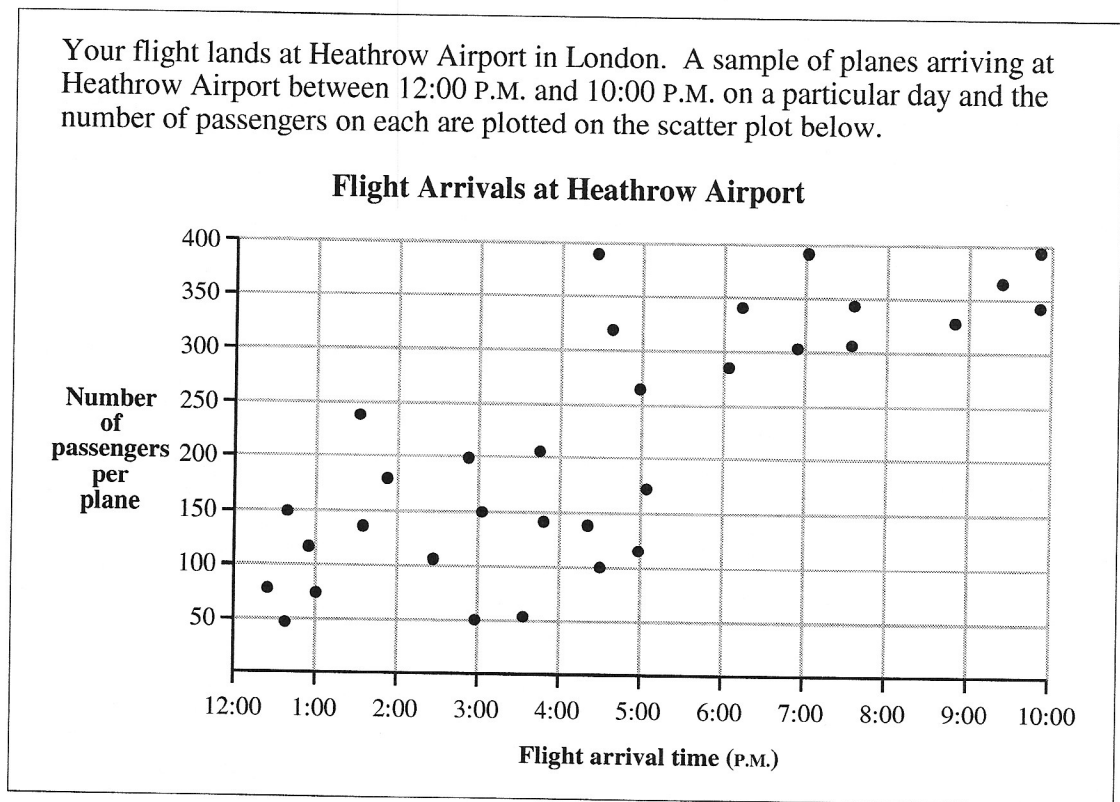

40. The scatter plot shows that in the
- A. afternoon fewer planes land than in the evening
  - B. evening there are more passengers per plane than in the afternoon
  - C. evening more planes land than in the afternoon
  - D. afternoon there are more passengers per plane than in the evening

### On Tour in London

41. While on a tour, you see a rectangular dock on the River Thames. The area of the surface of the dock can be represented by  $24y^2$  square units. The length is 6 times the width. What are the dimensions of the surface of the dock?
- A.  $2y$  units by  $12y$  units
  - B.  $4y$  units by  $24y$  units
  - C.  $y$  units by  $6y$  units
  - D.  $y$  units by  $24y$  units
42. The total cost of admission to an attraction in London is \$240.00 Canadian for 2 adults and 3 children. An adult admission is \$15 more than a child's. How much is an **adult** admission?
- A. \$42.00
  - B. \$45.00
  - C. \$48.00
  - D. \$57.00
43. Your tour stops at a castle. You stop for a rest  $\frac{1}{3}$  of the way up a stairway in the castle. If you climb 11 more steps, you will be  $\frac{1}{2}$  of the way up. How many steps are there in the stairway?
- A. 33 steps
  - B. 44 steps
  - C. 66 steps
  - D. 132 steps

Use the following information to answer question 44.

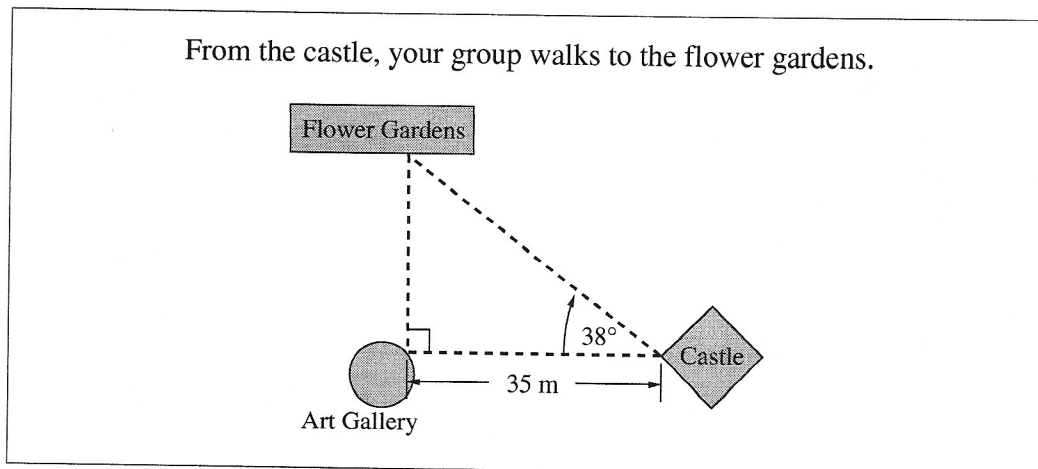

44. What is the shortest distance from the castle to the flower gardens?
- A. 57 m
  - B. 49 m
  - C. 44 m
  - D. 28 m

*You have now completed the multiple-choice questions.  
Proceed directly to the numerical-response questions.*

## Numerical-Response Questions

1. If  $a = 1.5$ ,  $b = -2$ , and  $c = -5$ , then  $\frac{(a-b)^2}{c^2}$  is equal to \_\_\_\_\_. (Round your answer to the nearest hundredth.)

Record your answer in the  
numerical-response section on the answer sheet.



2. While travelling in Europe, you exchange \$50.00 in Canadian money for local currency. You receive 8 identical bills and 4 identical coins. If each coin is worth \$1.24 Canadian, then the value of each bill, in Canadian currency, is \$ \_\_\_\_\_.

Record your answer in the numerical-response section on the answer sheet.

Use the following information to answer numerical-response question 3.

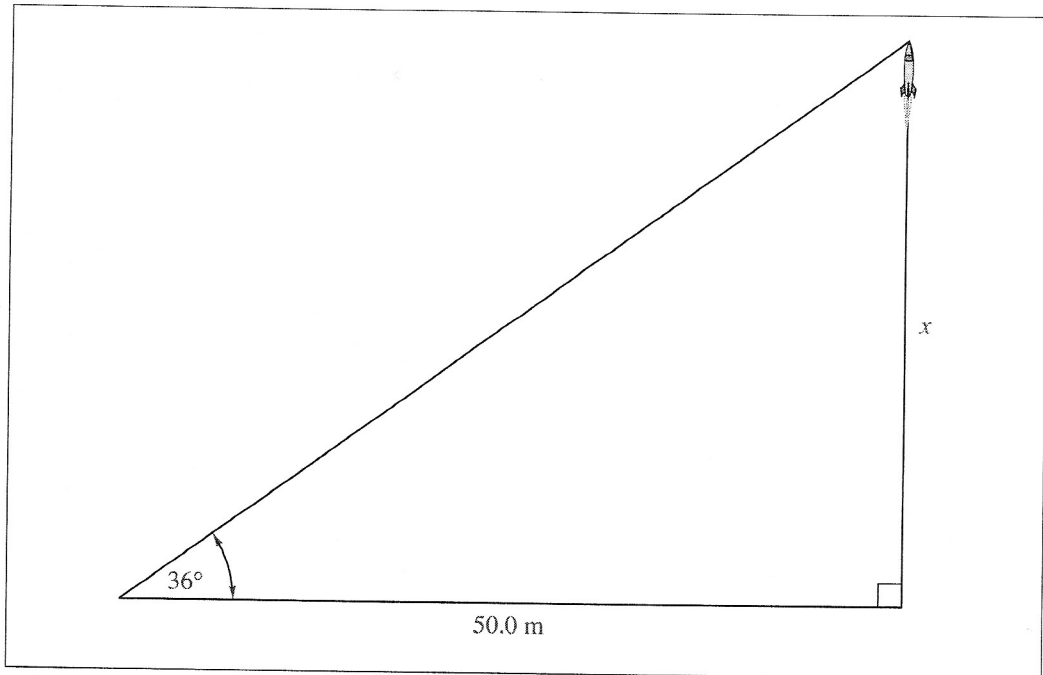





3. In a park, some people are launching model rockets. To find out the maximum height,  $x$ , that a rocket reaches, a person stands 50.0 m from the launch site and measures the angle from the ground to the rocket at its maximum height. If the angle is  $36^\circ$ , then the maximum height,  $x$ , of the rocket is \_\_\_\_\_ m.  
(Round your answer to the nearest tenth of a metre.)

Record your answer in the  
numerical-response section on the answer sheet.

4. What is the value of  $2^3 + 4^{-1}$  expressed as a decimal?

Record your answer in the  
numerical-response section on the answer sheet.

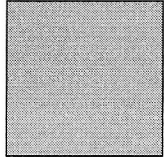
Use the following algebra-tile legend to answer numerical-response question 5.

 Shaded is positive	 = 1	 = $x$	 = $x^2$
 Unshaded is negative			

5. If  $x = 4.5$ , the value of the expression shown below is \_\_\_\_\_. (Round your answer to the nearest tenth.)

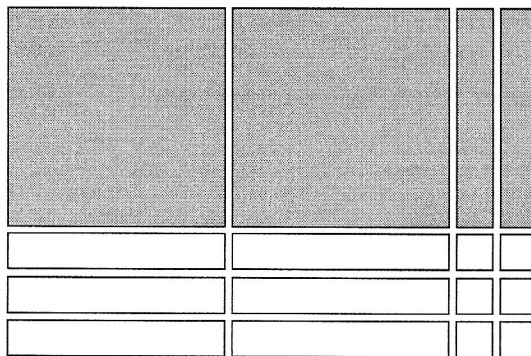

Record your answer in the numerical-response section on the answer sheet.

6. A foghorn sounds a blast for 2 seconds and then is silent for 8 seconds. This pattern continues for  $3\frac{1}{2}$  hours. How many blasts does the foghorn make in this period of time?

Record your answer in the  
numerical-response section on the answer sheet.

*You have now completed the test.  
If you have time, you may wish to check your answers.*

## Numerical-Response Questions

1. If  $a = 1.5$ ,  $b = -2$ , and  $c = -5$ , then  $\frac{(a-b)^2}{c^2}$  is equal to \_\_\_\_\_. (Round your answer to the nearest hundredth.)

Record your answer in the  
numerical-response section on the answer sheet.

2. While travelling in Europe, you exchange \$50.00 in Canadian money for local currency. You receive 8 identical bills and 4 identical coins. If each coin is worth \$1.24 Canadian, then the value of each bill, in Canadian currency, is \$ \_\_\_\_\_.

Record your answer in the  
numerical-response section on the answer sheet.

Use the following information to answer numerical-response question 3.

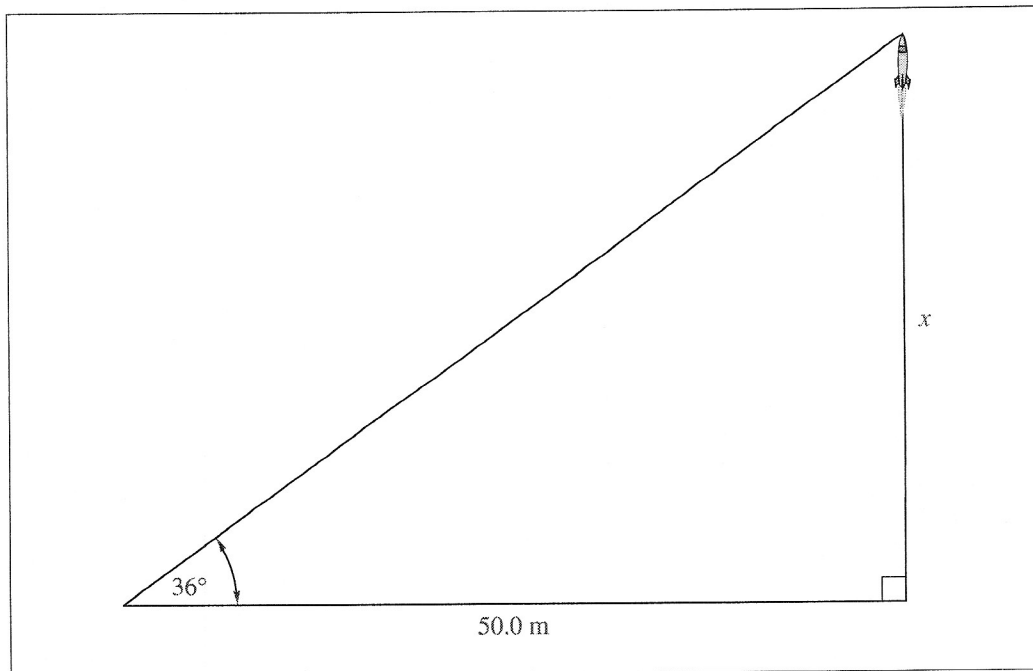

3. In a park, some people are launching model rockets. To find out the maximum height,  $x$ , that a rocket reaches, a person stands 50.0 m from the launch site and measures the angle from the ground to the rocket at its maximum height. If the angle is  $36^\circ$ , then the maximum height,  $x$ , of the rocket is \_\_\_\_\_ m.  
(Round your answer to the nearest tenth of a metre.)

Record your answer in the  
numerical-response section on the answer sheet.



4. What is the value of  $2^3 + 4^{-1}$  expressed as a decimal?

Record your answer in the  
numerical-response section on the answer sheet.

Use the following algebra-tile legend to answer numerical-response question 5.

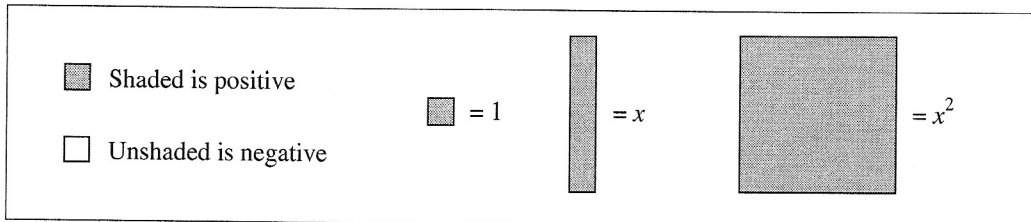

5. If  $x = 4.5$ , the value of the expression shown below is \_\_\_\_\_. (Round your answer to the nearest tenth.)

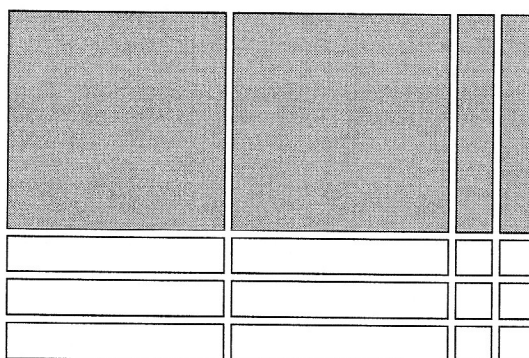

Record your answer in the numerical-response section on the answer sheet.

6. A foghorn sounds a blast for 2 seconds and then is silent for 8 seconds. This pattern continues for  $3\frac{1}{2}$  hours. How many blasts does the foghorn make in this period of time?

Record your answer in the numerical-response section on the answer sheet.

*You have now completed the test.  
If you have time, you may wish to check your answers.*

**Achievement Test 2000**  
**Grade 9 Mathematics**

Question	Key	Question	Key	Question	Key
1	D	23	C	NR1	0.49
2	D	24	A	NR2	5.63
3	D	25	B	NR3	36.3
4	C	26	D	NR4	8.25
5	A	27	A	NR5	16.5
6	C	28	D	NR6	1260
7	D	29	B		
8	A	30	D		
9	B	31	A		
10	A	32	A		
11	B	33	C		
12	A	34	B		
13	C	35	C		
14	B	36	D		
15	D	37	A		
16	B	38	D		
17	D	39	B		
18	C	40	B		
19	B	41	A		
20	B	42	D		
21	B	43	C		
22	A	44	C		