

# **Grade 9 Mathematics Online Practice Test - 2001**

**(Adapted from the 2001 Grade 9 Mathematics Achievement Test)**

Copyright 2005, the Crown in Right of Alberta, as represented by the Minister of Education, Alberta Education, Learner Assessment Branch, 44 Capital Boulevard, 10044 108 Street NW, Edmonton, Alberta T5J 5E6, and its licensors. All rights reserved.

**Special permission** is granted to **Alberta educators only** to reproduce, for educational purposes and on a non-profit basis, parts of this document that do **not** contain excerpted material.

Excerpted material in this document **shall not** be reproduced without the written permission of the original publisher (see credits, where applicable).

## Grade 9 Achievement Test

### Mathematics

#### *Description*

This test has two sections:

- one section has 44 multiple-choice questions, each worth one mark
- the other section has 6 numerical-response questions, each worth one mark

**This test was developed to be completed in 90 minutes; however, you may take an additional 30 minutes to complete the test.**

*You may write in this booklet, if you find it helpful. Make sure answers are placed on the answer sheet.*

#### *Instructions*

- You are expected to provide your own scientific calculator.
- Be sure that your calculator is in degree (DEG) mode.
- Manipulatives may be used for this test.
- Read each question carefully.
- Use **only** an **HB** pencil to mark your answer.
- If you change an answer, **erase** your first mark **completely**.
- Try to answer every question.
- Now turn this page and read the detailed instructions for answering multiple-choice and numerical-response questions.

### Multiple Choice

- Each question has four possible answers from which you are to choose the **correct** or **best** answer.

#### Example

If  $x = 3$ , what is the value of  $x + 8$ ?

- A. 10
- B. 11
- C. 12
- D. 13

#### Answer Sheet

A  B  C  D

- Locate the question number on the separate answer sheet provided and fill in the circle that corresponds to your choice.

### Numerical Response

- Record your answer on the answer sheet provided by writing it in the boxes and then filling in the corresponding circles.
- Enter the first digit of your answer in the left-hand box and leave any unused boxes blank.

#### Example 1

If  $(4^x)^3 = 4^{18}$ , what does  $x$  equal?

Record your answer in the numerical-response section on the answer sheet.

Solution:

$$(4^x)^3 = 4^{18}$$

$$4^{3x} = 4^{18}$$

$$3x = 18$$

$$x = 6$$

Record 6 on the answer sheet →

6			
-	-		
0	0	0	0
1	1	1	1
2	2	2	2
3	3	3	3
4	4	4	4
5	5	5	5
<input checked="" type="radio"/>	6	6	6
7	7	7	7
8	8	8	8
9	9	9	9

**Example 2**

James had a garden in the shape of a triangle. He knows its area and the length of one of its sides. This year, he enlarged the garden to form a trapezoidal shape. He knows the length of its longest side.

$$\text{Area of trapezoid} = \frac{h(a + b)}{2}$$

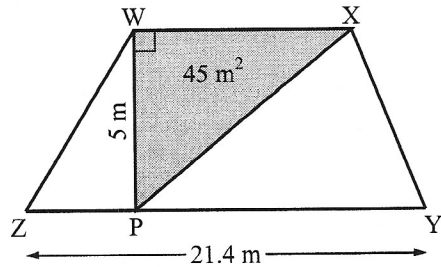

What is the total area of his garden now?

Record your answer in the numerical-response section on the answer sheet.

Solution:

$$\text{Area of triangle} = \frac{ab}{2}$$

$$\text{Area of triangle} = \frac{(WP)(WX)}{2}$$

$$45 \text{ m}^2 = \frac{(5 \text{ m})(WX)}{2}$$

$$WX = \frac{2(45 \text{ m}^2)}{5 \text{ m}}$$

$$WX = 18 \text{ m}$$

$$\text{Area of trapezoid} = \frac{h(a + b)}{2}$$

$$= \frac{WP(WX + ZY)}{2}$$

$$= \frac{5 \text{ m}(18 \text{ m} + 21.4 \text{ m})}{2}$$

$$= \frac{5 \text{ m}(39.4 \text{ m})}{2}$$

$$= \frac{197 \text{ m}^2}{2}$$

$$= 98.5 \text{ m}^2$$

The area of the new garden is  $98.5 \text{ m}^2$ .

Record 98.5 on the answer sheet →

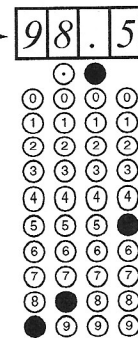

## Connections within Mathematics

Use the following information to answer question 1.

A right-angled triangle is shown below.

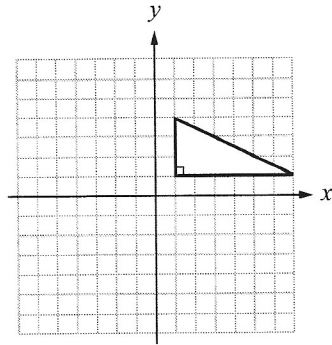

1. Which of the following diagrams represents the triangle above when it is reflected using the  $x$ -axis as the line of reflection?

A.

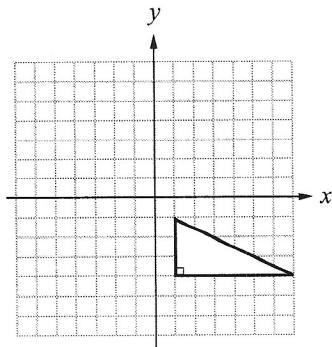

B.

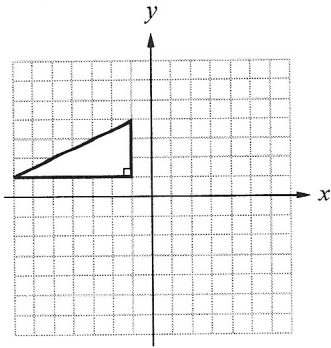

C.

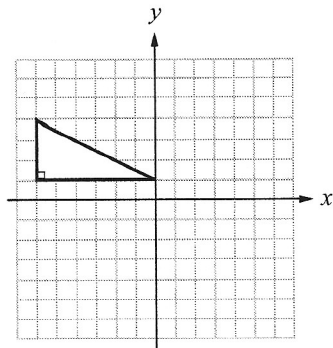

D.

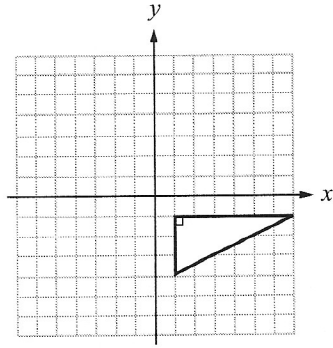

Use the following algebra-tile legend to answer questions 2 and 3.

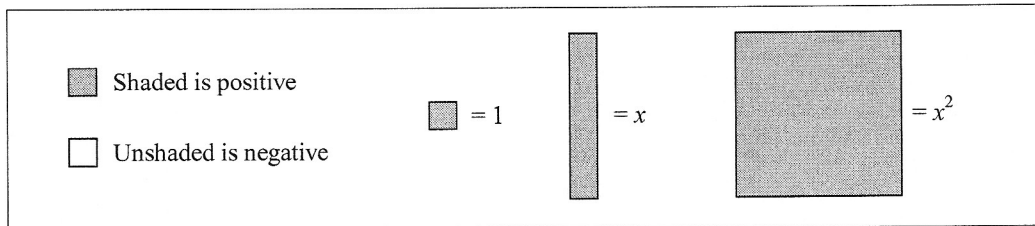

2. Kent and Larissa go to a movie. Admission is  $x$  dollars per person. They have a \$5 discount coupon. Which of the following algebra-tile models represents the total cost for what they pay?

A.

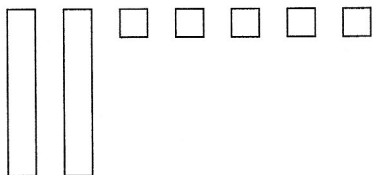

B.

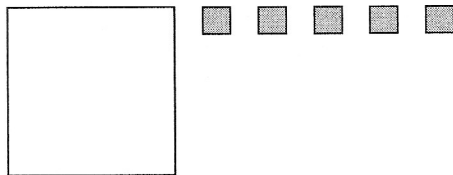

C.

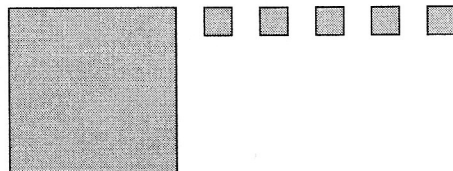

D.

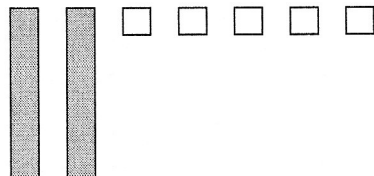

Use the following algebra-tile model to answer question 3.

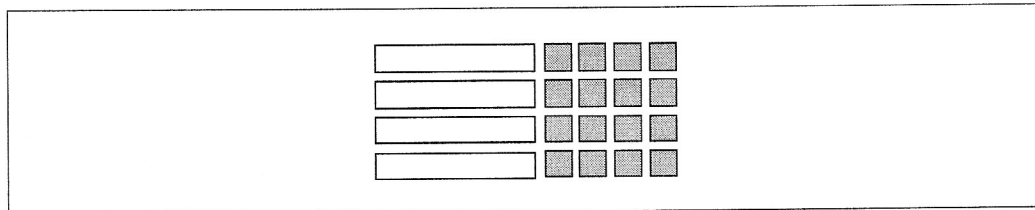

3. Which of the following products is represented by the algebra-tile model above?

- A.  $4(-x + 4)$
- B.  $4(x - 4)$
- C.  $2(-2x + 4)$
- D.  $2(2x - 4)$



Use the following information to answer question 4.

On the grid below, the original image is  $\triangle ABC$  and the dilatation image is  $\triangle A'B'C'$ .

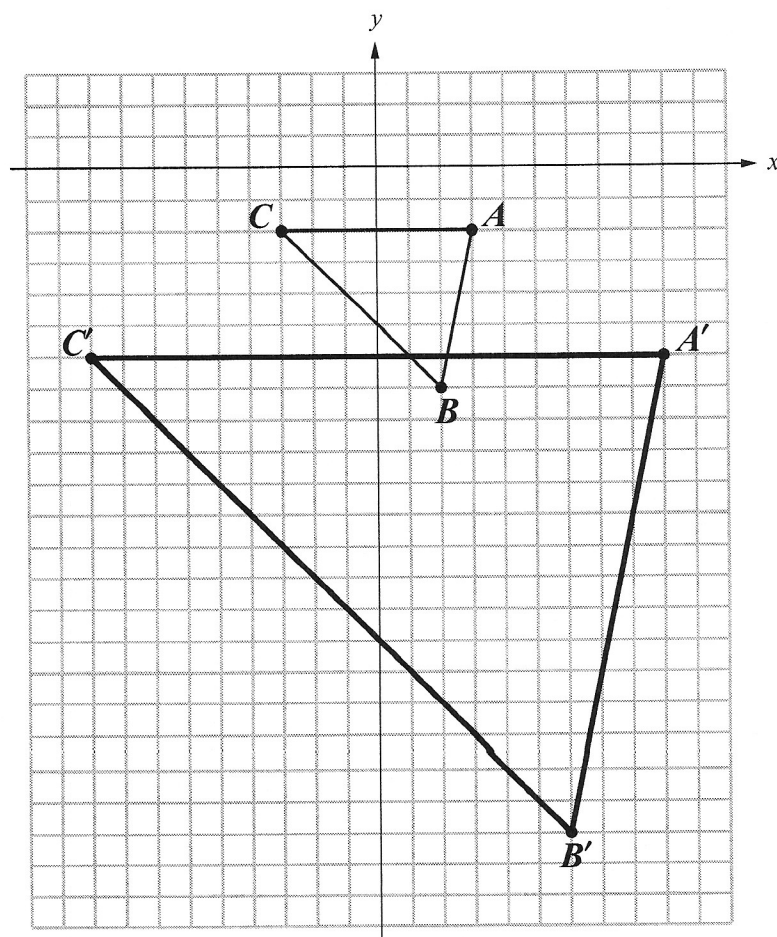

4. The scale factor of the dilatation is

- A.  $\frac{1}{4}$
- B.  $\frac{1}{3}$
- C. 3
- D. 4

Use the following diagram to answer question 5.

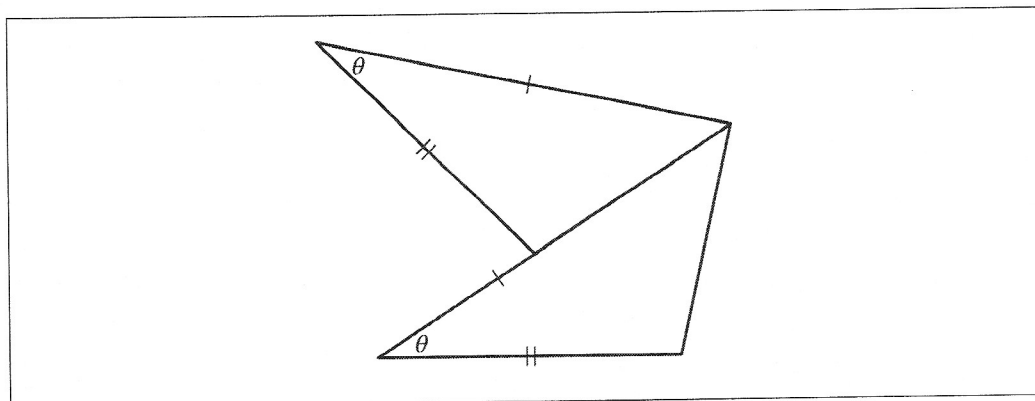

5. Which set of conditions for congruency proves that the triangles above are congruent?

- A. ASA
- B. AAS
- C. SSA
- D. SAS

6. Which of the following number lines represents the solution to the inequality  $x + 8 > 3x - 6, x \in \mathbb{R}$ ?

- A.
- B.
- C.
- D.

7. The calculator keystroke sequence that would give the solution of  $\frac{28+7}{5 \times (4+3)}$  is

A. 28  7  5  4  3

B. (   7   5  (   3

C. 28  7  (   (   3

D. (   7   (   (   3

8. A square has an area of  $196 \text{ cm}^2$ . Given that  $\pi = 3.14$ , what is the area of the largest circle that can be drawn within this square?

- A.  $615.44 \text{ cm}^2$
- B.  $153.86 \text{ cm}^2$
- C.  $62.42 \text{ cm}^2$
- D.  $43.96 \text{ cm}^2$

9. In a math puzzle, you have 3 consecutive odd numbers whose sum is 219. What is the value of the largest number?

- A. 77
- B. 75
- C. 73
- D. 71

10. When simplified, the expression  $\frac{18x^2y^3 + 12x^4y^2 - 15xy^4}{3x^2y}$  is equivalent to

- A.  $6y^2 + 4x^2y - 5xy^3$
- B.  $6xy^2 + 4xy - 5xy^3$
- C.  $6y^2 + 4x^2y - 5x^{-1}y^3$
- D.  $6xy^2 + 4xy - 5x^{-1}y^3$

11. In a class of 27 students who are studying the history of music, there are  $(3x + 2)$  students studying rock and roll,  $(2x + 1)$  students studying rap, and  $(7x)$  students studying jazz. The actual number of students who are studying each musical category is

- A. 8 in rock and roll, 5 in rap, and 14 in jazz
- B. 7 in rock and roll, 6 in rap, and 14 in jazz
- C. 6 in rock and roll, 7 in rap, and 14 in jazz
- D. 5 in rock and roll, 8 in rap, and 14 in jazz

12. The numbers  $-20$ ,  $\frac{5}{11}$ ,  $0$ ,  $42$ , and  $24$  all belong to the

- A. rational number system
- B. integral number system
- C. whole number system
- D. natural number system

Use the following information to answer question 13.

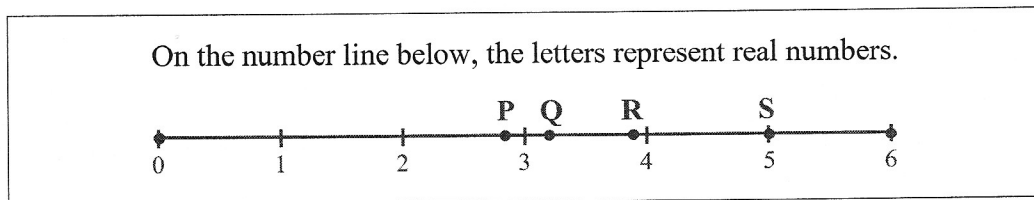

13. On the number line, the approximate value of  $\sqrt{10}$  is represented by the letter

- A. P
  - B. Q
  - C. R
  - D. S
- 

14. The solution to  $(5.2 \times 10^{-3}) \times (1.5 \times 10^2)$  is

- A.  $6.7 \times 10^{-1}$
- B.  $7.8 \times 10^{-1}$
- C.  $6.7 \times 10^{-6}$
- D.  $7.8 \times 10^{-6}$

15. A paper bag contains 20 green, 15 blue, 15 white, 8 pink, and 2 orange bubble gums. What is the probability that a person will randomly draw a blue or a green bubble gum out of the bag on the first try?

A.  $\frac{2}{35}$

B.  $\frac{7}{12}$

C.  $\frac{1}{3}$

D.  $\frac{1}{4}$

Use the following scatter plot to answer question 16.

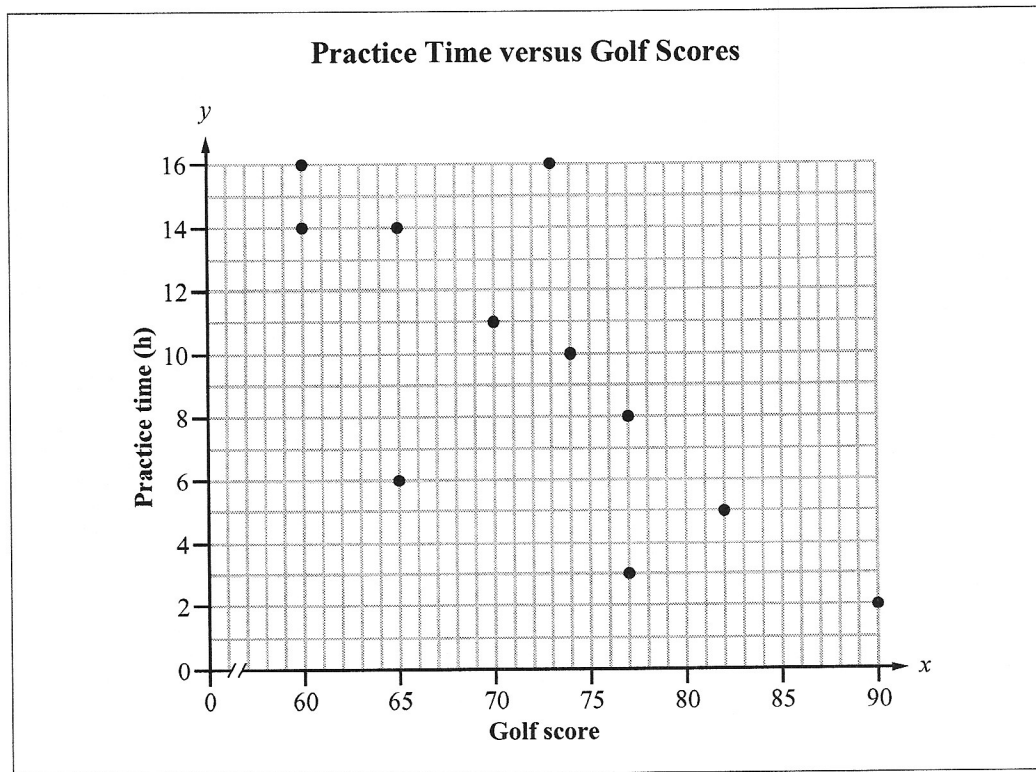

16. If the line of best fit were drawn on the scatter plot above, the coordinate point that would lie closest to the line of best fit would be

- A. (60, 14)
- B. (65, 6)
- C. (73, 16)
- D. (77, 8)

17. A car travelling at a speed of 105 km/h uses 8.2 L of gas per 100 km. If the vehicle travels for 72 min, how many litres of gas does it use?

- A. 10.33 L
- B. 12.20 L
- C. 12.80 L
- D. 14.63 L

18. Ms. Carlson put \$3.75 into a parking meter. She used twice as many nickels as quarters, and three fewer dimes than quarters. How many dimes did she use?

- A. 3
- B. 6
- C. 9
- D. 18



Use the following information to answer question 19.

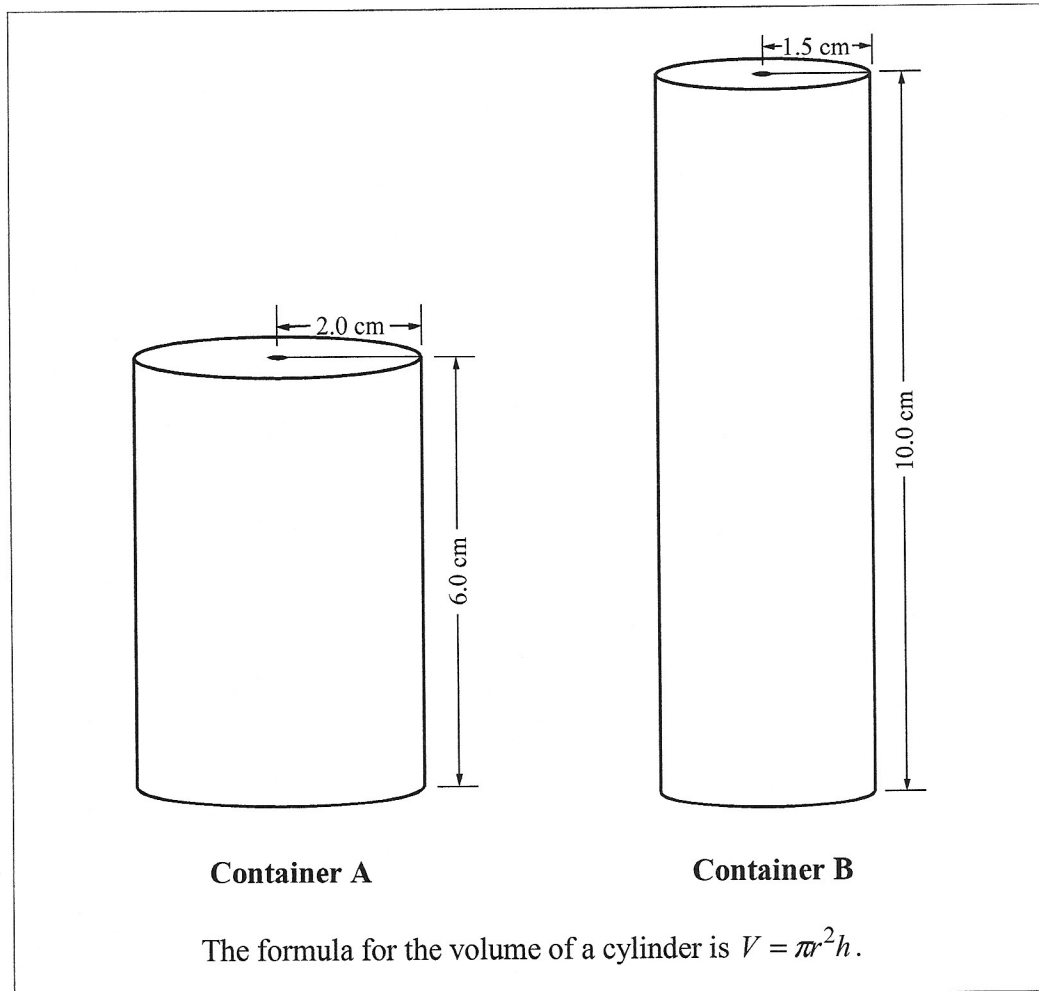

19. The volume of container A is how much greater than the volume of container B?

- A. 4.71 cm<sup>3</sup>
- B. 9.42 cm<sup>3</sup>
- C. 70.65 cm<sup>3</sup>
- D. 75.36 cm<sup>3</sup>

## Mathematics of Farming

Farmers use math everyday. The following questions show ways in which farmers may use math in their daily work.

Photograph of a farm is unavailable for electronic posting.

—courtesy of Steve and Alice Weleschuk

20. A farmer's hens laid 50 eggs. Of the 50 eggs, 35 were white and 15 were brown. When the farmer gathered the eggs, what is the probability that the first egg he randomly picked was a white egg?

A.  $\frac{1}{50}$

B.  $\frac{1}{35}$

C.  $\frac{15}{35}$

D.  $\frac{35}{50}$

21. Some of the hens became sick. At 9:00 A.M. on Saturday, 3 hens were sick. Every half hour, 2 more hens got sick. If this pattern were to continue, the number of hens that would be sick at 2:00 P.M. can be represented by the expression

A.  $3 \times 2^9$

B.  $3 \times 2^{10}$

C.  $3 + (2 \times 10)$

D.  $3 + (3 \times 10)$

Use the following information to answer question 22.

The farmer bought some new hens. The following table shows the number of eggs laid ( $E$ ) by some of these hens in one week and the number of hens ( $H$ ) that laid them.

Number of hens ( $H$ )	Number of eggs laid ( $E$ )
2	12
3	19
4	26

22. Which of the following equations represents the relationship between the number of eggs laid in one week and the number of hens that laid them?

- A.  $E = 6H$
- B.  $E = 6H + 1$
- C.  $E = 7H - 2$
- D.  $E = 7H - 7$

23. In the fall, the farmer sells his grain. Which of the following graphs shows the relationship between grain price and farm income?

A.

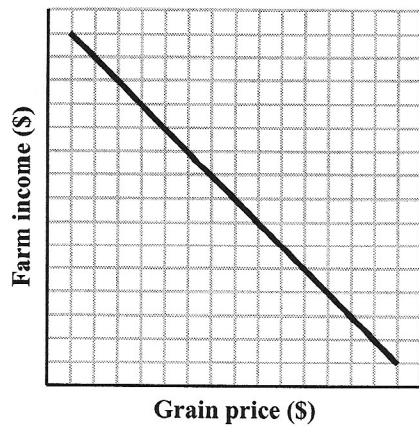

B.

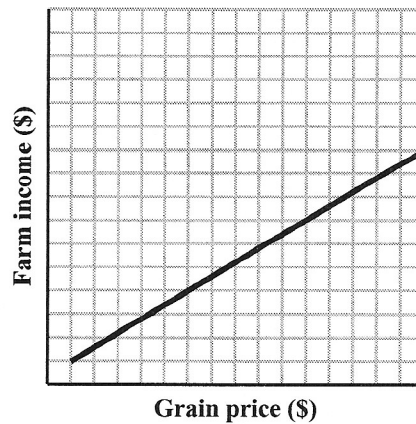

C.

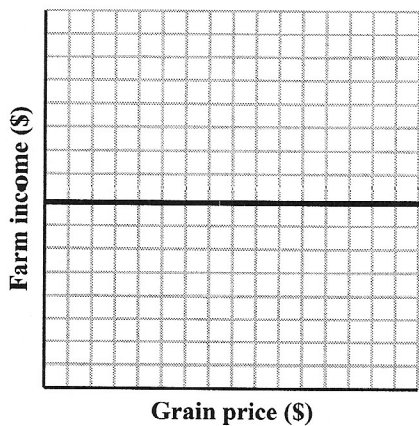

D.

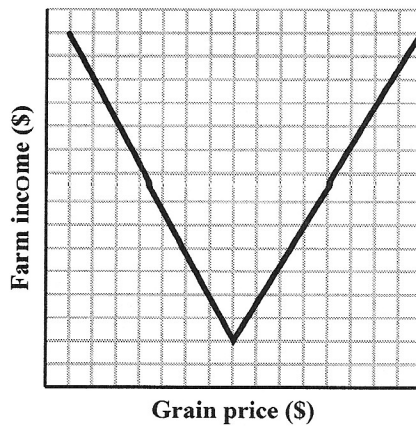

24. The farmer and his son leave a barn at the same time and walk in opposite directions checking a fence line. The son walks at a speed of 3.5 km/h, and the farmer at 4.0 km/h. How much time will have elapsed when the farmer and his son are 2.5 km apart?

- A.  $\frac{1}{5}$  h
- B.  $\frac{1}{3}$  h
- C. 3 h
- D. 5 h

## Mathematics at the Cabin

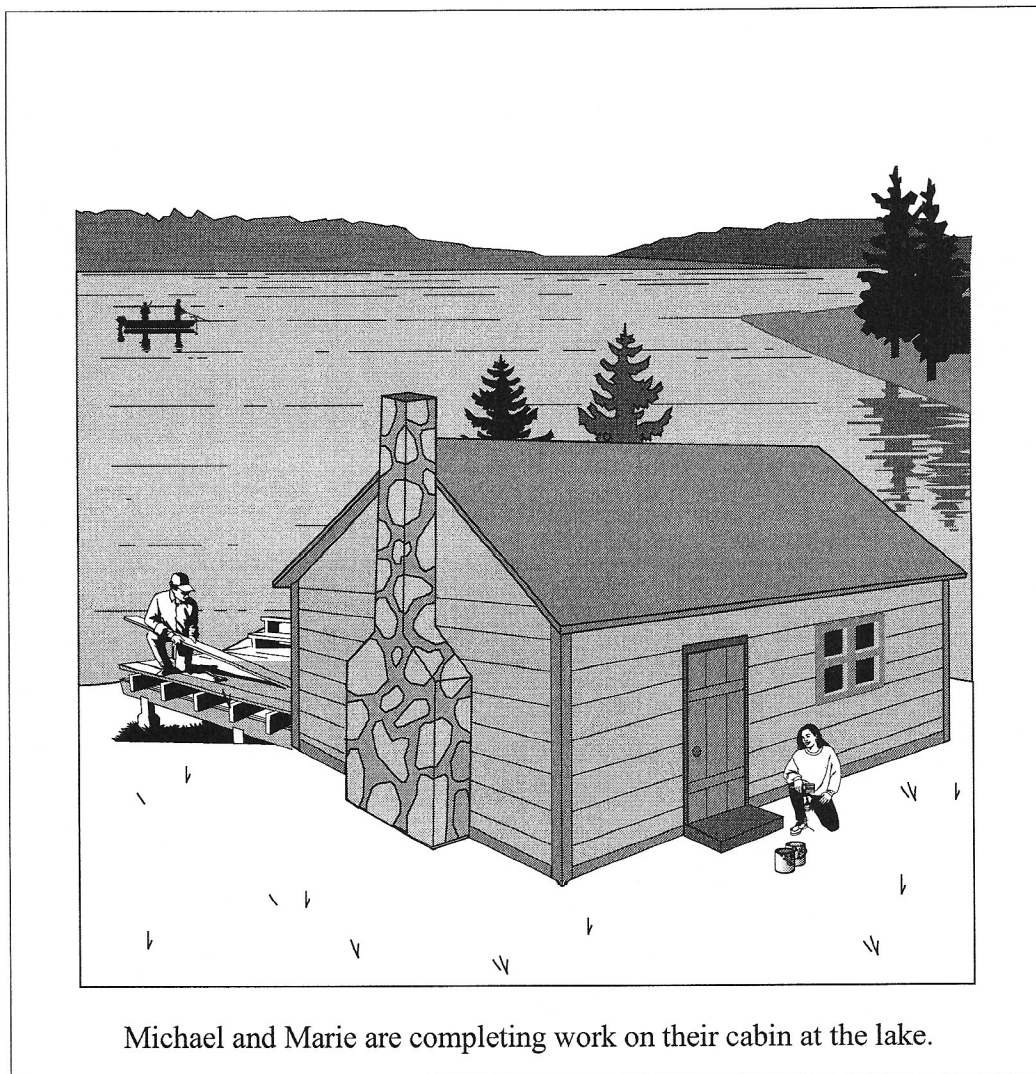

Michael and Marie are completing work on their cabin at the lake.

Use the following information to answer question 25.

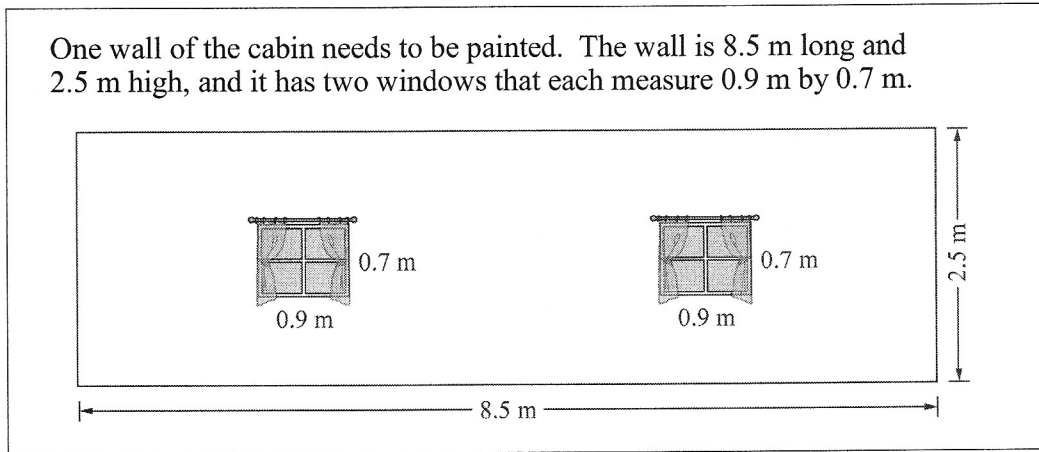

25. The area of the wall that needs to be painted, to the nearest tenth, is

- A. 20.0 m<sup>2</sup>
- B. 20.6 m<sup>2</sup>
- C. 21.3 m<sup>2</sup>
- D. 22.5 m<sup>2</sup>



26. Michael and Marie select wood to build a fence around their cabin property. Out of every 10 pieces of wood they look at, 7 of them are of a good quality and 3 of them have a defect. If Michael and Marie each select 1 piece of wood from a different pile, what is the probability that they both select a good-quality piece?

A.  $\frac{6}{100}$

B.  $\frac{9}{100}$

C.  $\frac{14}{100}$

D.  $\frac{49}{100}$

27. Michael has a cylindrical rainwater barrel that needs a lid. Which of the following equations could Michael use to determine the radius of the lid?

A.  $r = \frac{2C}{\pi}$

B.  $r = \frac{C}{2\pi}$

C.  $r = \frac{\pi}{2C}$

D.  $r = \frac{2\pi}{C}$

28. Michael buys a fan for the cabin. The store purchased the fan for \$60. The store then marked up the price by 20%. When the fan went on sale, its price was decreased by 20%. What was the sale price of the fan that Michael bought?

A. \$57.60

B. \$60.00

C. \$60.20

D. \$72.00

Use the following information to answer question 29.

Marie made an arrangement to buy a used television for a total cost of \$200. She made a \$50 down payment and arranged to make 6 equal payments to pay the balance.

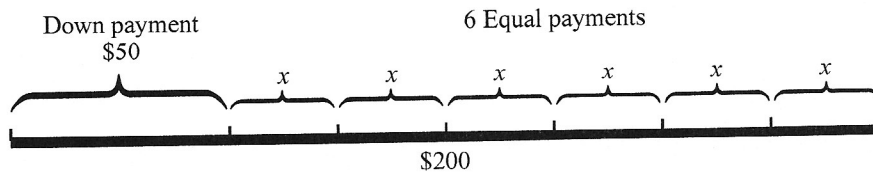

29. Which of the following formulas can Marie use to determine the amount of each of the 6 equal payments?

- A.  $x = 200 \div 6 + 50$
- B.  $x = (200 + 50) \div 6$
- C.  $x = 200 \div 6 - 50$
- D.  $x = (200 - 50) \div 6$

Use the following information to answer question 30.

Marie is concerned about the cost of energy consumption at the cabin. Using her neighbour's power bills for the past two years, Marie graphed the energy consumption of the neighbour's cabin, as shown below.

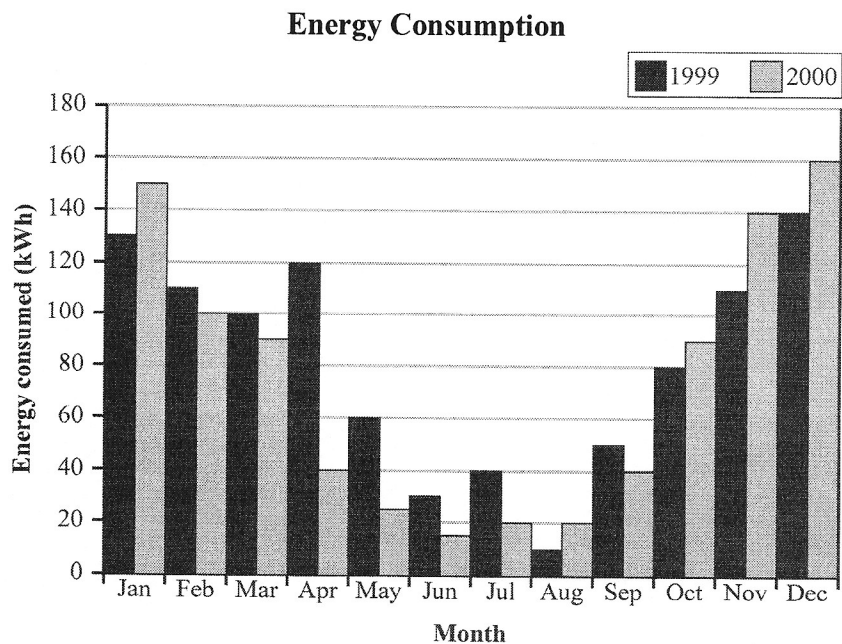

30. When Marie compares the energy consumption for the two years, she realizes that the
- A. February 2000 consumption was the same as the February 1999 consumption
  - B. April 2000 consumption was three times as great as the April 1999 consumption
  - C. July 2000 consumption was one-half the July 1999 consumption
  - D. August 2000 consumption was one-half the August 1999 consumption
- 
31. Michael is 1.7 m tall. At 2:00 P.M., he casts a shadow 90 cm long and the storage shed casts a shadow 305 cm long. The height of the storage shed, to the nearest tenth of a metre, is
- A. 0.5 m
  - B. 2.0 m
  - C. 4.7 m
  - D. 5.8 m

Use the following information to answer question 32.

Michael stacks boxes of building materials in his storage shed.

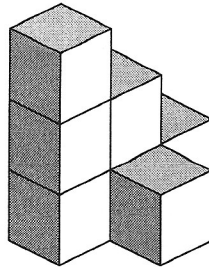

32. Which of the following sets of views represents the layout of Michael's boxes?

A.

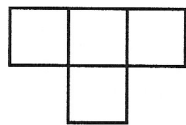

Plan or Top view

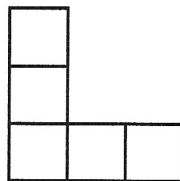

Front view

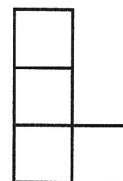

Side view

B.

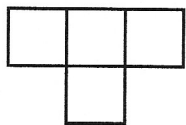

Plan or Top view

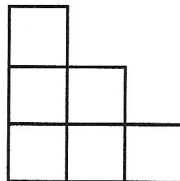

Front view

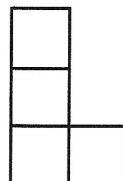

Side view

C.

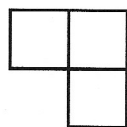

Plan or Top view

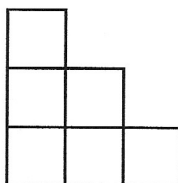

Front view

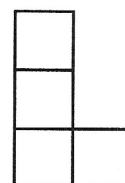

Side view

D.

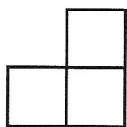

Plan or Top view

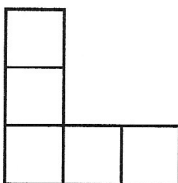

Front view

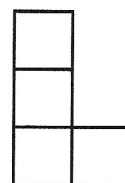

Side view

Use the following information to answer question 33.

Marie wants to buy a used canoe. She found the advertisement shown below; however, the last two digits of the phone number were missing.

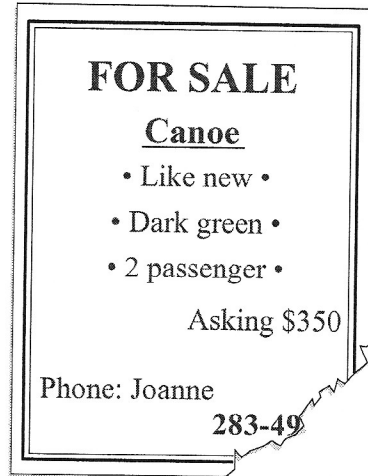

33. What is the maximum number of calls that Marie will have to make to be certain of reaching the person who placed the advertisement?

- A. 100
- B. 90
- C. 81
- D. 72

## Mathematics and Sports

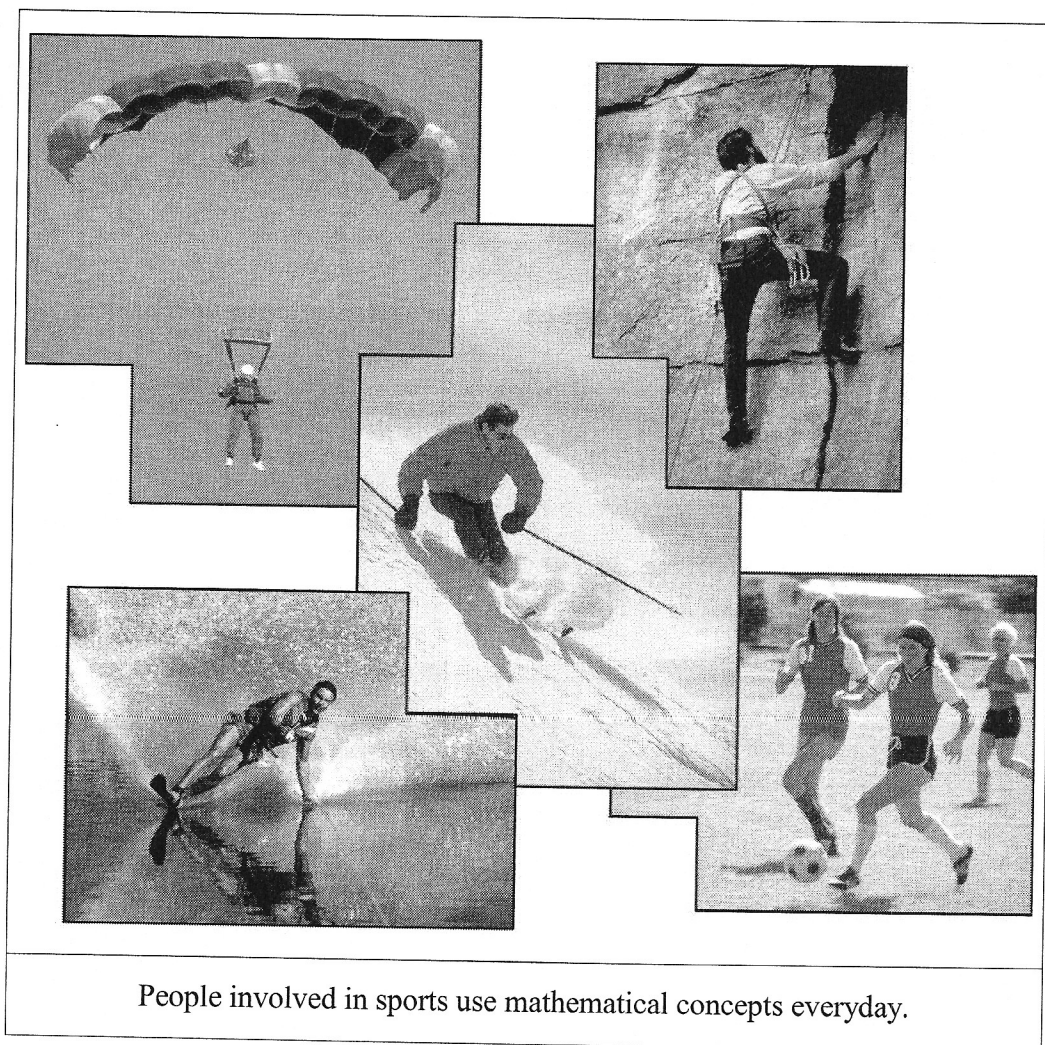

People involved in sports use mathematical concepts everyday.

34. A parachutist jumps out of a plane that is flying at an altitude of 3 km, and she immediately opens her parachute. If she falls at an average rate of 24 m/s, she will reach the ground in
- A. 1.25 s
  - B. 12.5 s
  - C. 125 s
  - D. 1 250 s
35. At a particular ski hill, the total cost of lift tickets for 2 adults and 3 children is \$240. An adult lift ticket is \$15 more than a child's. How much is an **adult** lift ticket?
- A. \$42
  - B. \$45
  - C. \$48
  - D. \$57
36. If it takes one snowmaking machine 6 h to cover a portion of a ski hill with snow and another snowmaking machine 4 h to cover the same area, how long will it take to cover the same area if both machines are working at the same time?
- A. 0.42 h
  - B. 2.4 h
  - C. 5 h
  - D. 10 h

Use the following information to answer questions 37 and 38.

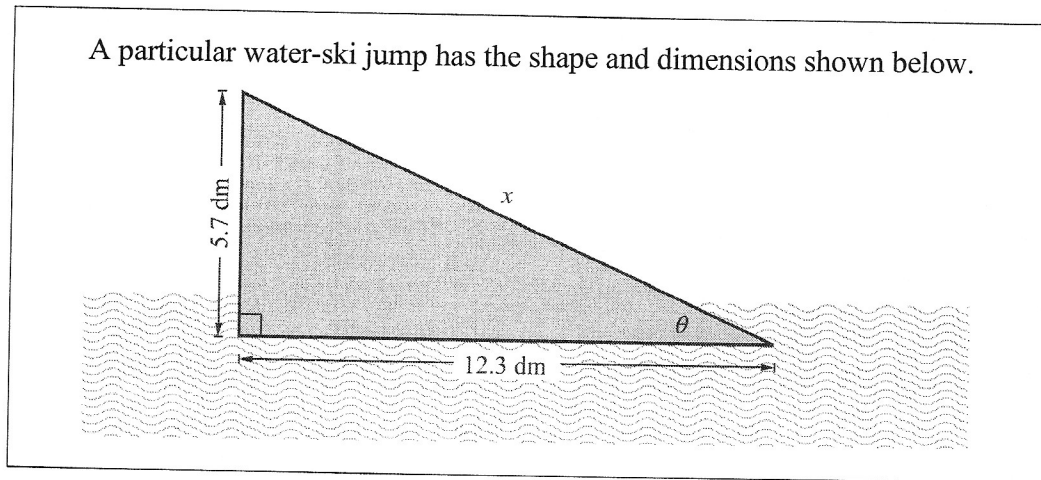

37. What is the length of side  $x$  of the ramp?

- A. 183.87 dm
- B. 18.0 dm
- C. 13.56 dm
- D. 6.6 dm

38. What is the angle of elevation ( $\theta$ ), to the nearest degree, of the ramp?

- A.  $25^\circ$
- B.  $28^\circ$
- C.  $62^\circ$
- D.  $65^\circ$



Use the following information to answer question 39.

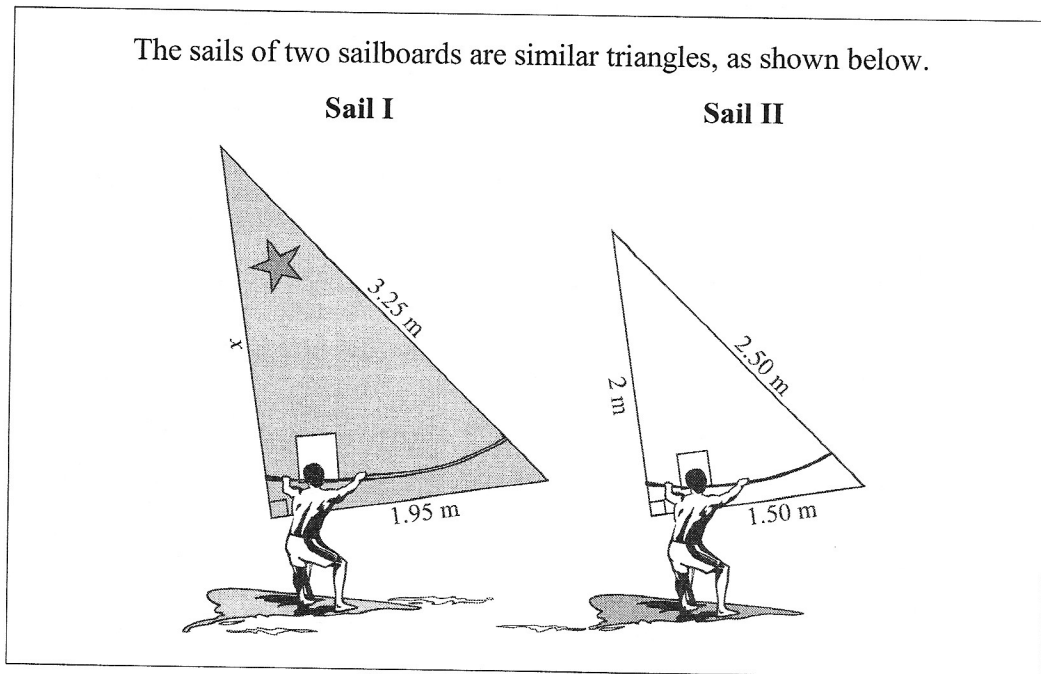

39. What is the length of side  $x$  of sail I?

- A. 2.45 m
- B. 2.6 m
- C. 2.75 m
- D. 3.8 m

## Mathematics and Camping



The Smith family is going camping during their summer vacation.

Use the following information to answer question 40.

The Smiths need to purchase a tent. A sporting goods store has a tent set up in a display area. The tent has rectangular walls, a covered door, and a square-based pyramidal roof, as shown below.

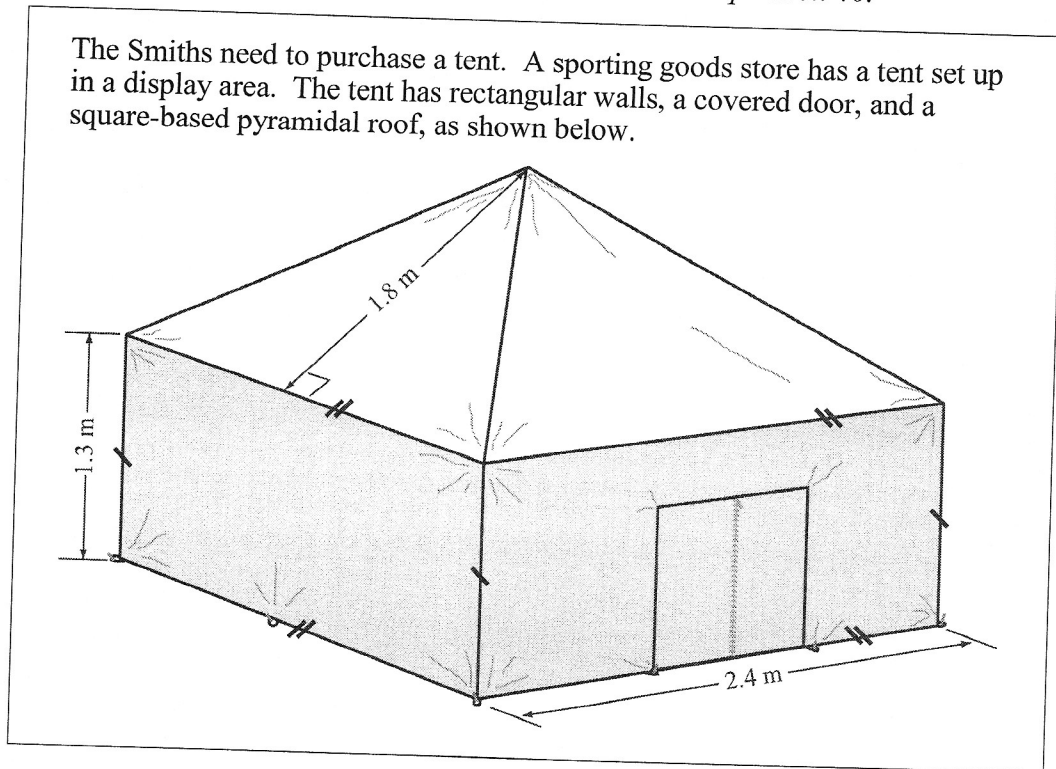

40. Excluding the floor and seams, the amount of material that was used to make this tent was

- A.  $16.32 \text{ m}^2$
- B.  $17.16 \text{ m}^2$
- C.  $21.12 \text{ m}^2$
- D.  $26.88 \text{ m}^2$

Use the following information to answer question 41.

For a five-night camping trip, the Smith family had budgeted to spend an average of \$80 per night for campground fees, food, and entertainment. Their actual costs for the first four nights are recorded below.

	<b>First Night</b>	<b>Second Night</b>	<b>Third Night</b>	<b>Fourth Night</b>	<b>Fifth Night</b>
<b>Amount Spent</b>	\$130	\$95	\$45	\$70	$x$

41. In order to remain within their total budget, the maximum amount that the Smith family can spend on the fifth night is
- A. \$85
  - B. \$80
  - C. \$68
  - D. \$60

42. The campground owner surveys the number of campers that arrive at different times of the day. He finds that, generally, more campers arrive later in the day. Which of the following scatter plots best represents the campground owner's findings?

A.

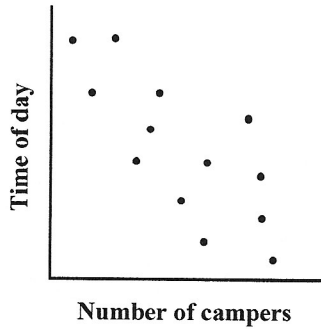

B.

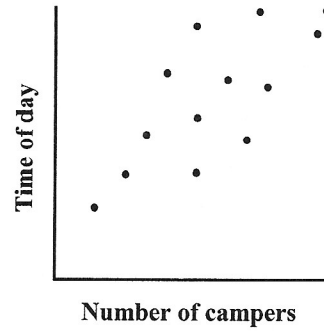

C.

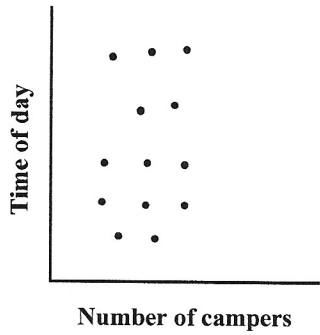

D.

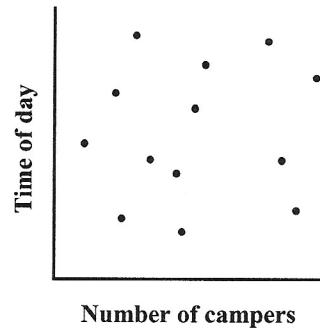

Use the following information to answer question 43.

At a campground, an outdoor stage is directly north of a small store, and the shower building is directly east of the store, as shown below.

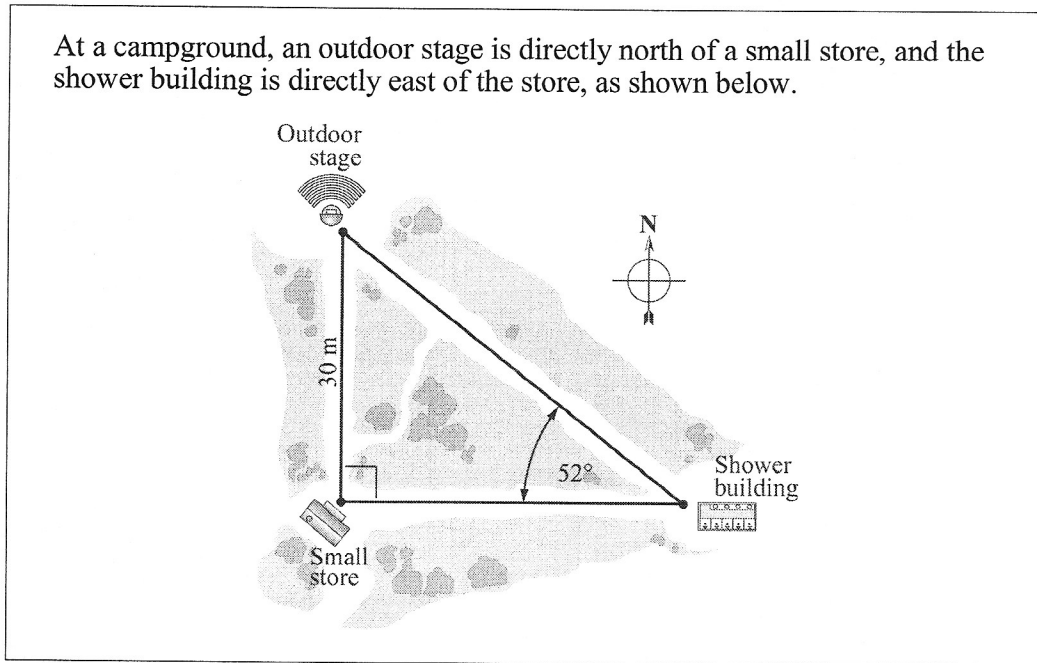

43. The distance from the outdoor stage to the shower building, to the nearest metre, is

- A. 18 m
- B. 24 m
- C. 38 m
- D. 49 m

Use the following information to answer question 44.

The Smiths think of a plan to save spending money for next year's trip. They will save 2 quarters the first month and then double the number of quarters each month thereafter.

<b>Month</b>	1	2	3	4	
<b>Quarters</b>	2	4	8	16	

44. How many quarters will the Smiths have to save during the 12th month?

- A. 4 096
- B. 2 048
- C. 144
- D. 24

*You have now completed the multiple-choice questions.  
Proceed directly to the numerical-response questions.*

### Numerical-Response Questions

1. If  $a = 1.5$ ,  $b = -2$ , and  $c = -5$ , then  $\frac{(a-b)^2}{c^2}$  is equal to \_\_\_\_\_. (Round your answer to the nearest hundredth.)

Record your answer in the  
numerical-response section on the answer sheet.



2. While travelling in Europe, you exchange \$50.00 in Canadian money for local currency. You receive 8 identical bills and 4 identical coins. If each coin is worth \$1.24 Canadian, then the value of each bill, in Canadian currency, is \$ \_\_\_\_\_.

Record your answer in the  
numerical-response section on the answer sheet.

Use the following information to answer numerical-response question 3.

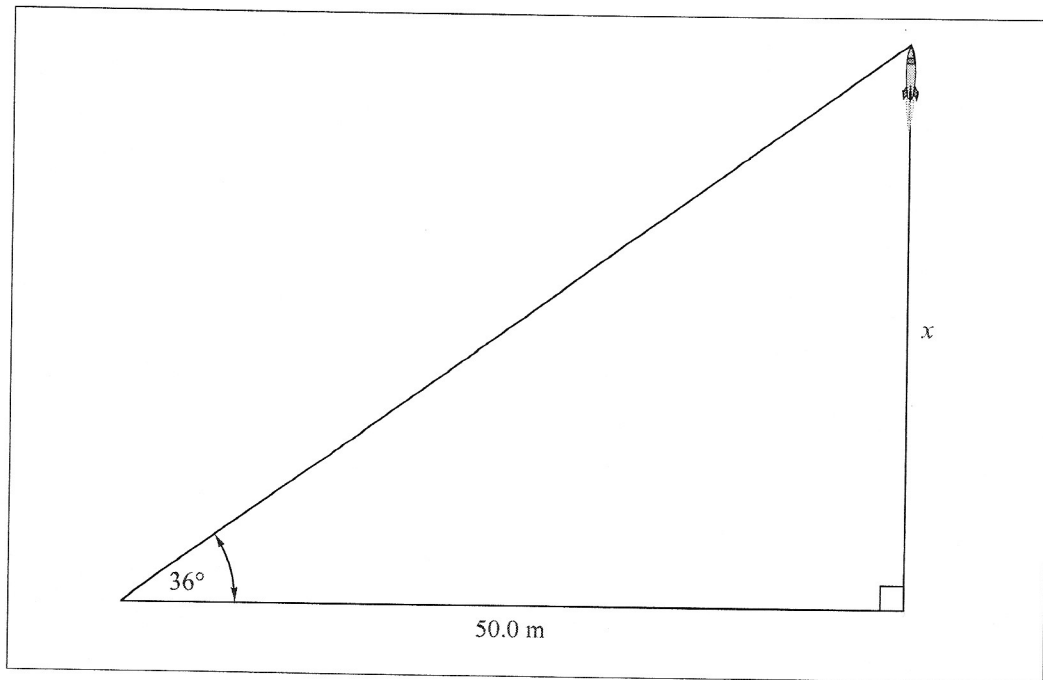

3. In a park, some people are launching model rockets. To find out the maximum height,  $x$ , that a rocket reaches, a person stands 50.0 m from the launch site and measures the angle from the ground to the rocket at its maximum height. If the angle is  $36^\circ$ , then the maximum height,  $x$ , of the rocket is \_\_\_\_\_ m.  
(Round your answer to the nearest tenth of a metre.)

Record your answer in the  
numerical-response section on the answer sheet.

Use the following information to answer numerical-response question 4.

Two companies advertise the following labour costs for car repair.

**A-1 Car Repair**

Cost = \$31.60 per hour plus a \$45 service charge

**Classix Car Repair**

Cost = \$41.70 per hour plus a \$30 service charge

4. If a particular repair takes 6 hours at A-1, but only 5 hours at Classix, how much money would a customer save by going to A-1 Car Repair?

Record your answer in the  
numerical-response section on the answer sheet.

Use the following algebra-tile legend to answer numerical-response question 5.

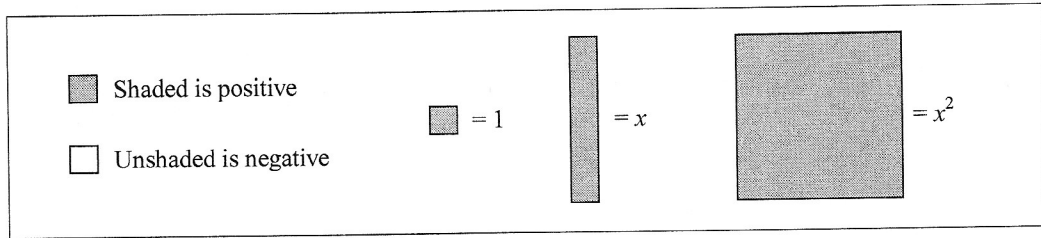

5. If  $x = 4.5$ , the value of the expression shown below is \_\_\_\_\_. (Round your answer to the nearest tenth.)

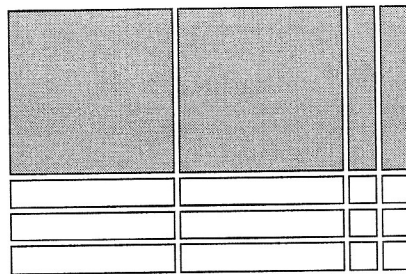

Record your answer in the numerical-response section on the answer sheet.

6. A rectangle has the dimensions  $(5x + 6)$  by  $(2x + 1)$ . If  $x = 4$  m, then the area of the rectangle is \_\_\_\_\_  $\text{m}^2$ .

Record your answer in the  
numerical-response section on the answer sheet.

*You have now completed the test.  
If you have time, you may wish to check your answers.*